



Lifelong
Learning
Programme



ENJOY LANGUAGE



Enjoy Language within Tourism

MATERIAL PACKAGE
for teachers, trainers
and the tourism sector in general

A project financed under the Life Long Learning Programme
(LLP-Ldv/TOI/SE/11/1383 - 2011-1-SE1-LEO05-08376)



www.enjoy-language.se

ACTIVITY TOURISM WORD CLOUD





ACTIVITY TOURISM WORD CLOUD







ACTIVITY TOURISM WORD CLOUD



AGRO-TOURISM WORD CLOUD



VERBS	NOUNS	ADJECTIVES	ADVERBS



AGRO-TOURISM WORD CLOUD



PLACES	ACTIVITIES	FEELINGS	FOOD AND DRINKS



LEISURE TOURISM WORD CLOUD



AGRO-TOURISM VIDEO SCRIPT



recreation	agro-tourist	outdoor	unique experience



LEISURE TOURISM WORD CLOUD



TO MAKE, TO SPREAD, TO SLEEP, TO MAKE, TO MELT,
TO LEAVE, TO WANT, TO LONG, TO SLEEP NEG., TO BE,
TO BE GOING TO, TO BE UP TO, CAN



NEW YORK, NEW YORK

Frank Sinatra, 1966

Start _____ the news, I _____ today
I _____ to be a part of it - New York, New York
These vagabond shoes, _____ to stray
Right through the very heart of it - New York, New York

I want to wake up in a city, that _____
And find I'm king of the hill - top of the heap

These little town blues, _____ away
I'll make a brand new start of it - in old New York
If I can _____ it there, I'll _____ it anywhere
It's up to you - New York, New York

New York, New York
I want to wake up in a city that never _____
And find I' _____ a number one, top of the list, king of the hill
A number one

These little town blues, are melting away
I' _____ to make a brand new start of it - in old New York
And if I' _____ make it there, I'm going to make it anywhere
It' _____ you - New York New York





CULTURAL TOURISM WORD CLOUD





TOURISM DISCUSSION CARDS 1



ENJOY LANGUAGE

TOURISM DISCUSSION CARDS

www.enjoy-language.se

A project financed under the Life Long Learning Programme
(LLP-Ldv/TOI/SE/11/1383 - 2011-1-SE1-LEO05-08376)

TOURISM DISCUSSION CARDS

What is tourism?



www.enjoy-language.se

TOURISM DISCUSSION CARDS

Where is the best place
to go on holiday?



www.enjoy-language.se

TOURISM DISCUSSION CARDS

Where can you go
scuba diving in Europe?



www.enjoy-language.se

TOURISM DISCUSSION CARDS

What is the best package
holiday type for families with
small children?



www.enjoy-language.se

TOURISM DISCUSSION CARDS

Where is the best relaxing
holiday destination for a
young couple?



www.enjoy-language.se

TOURISM DISCUSSION CARDS

How do you get a
last minute package holiday?



www.enjoy-language.se

TOURISM DISCUSSION CARDS

Where is the best
holiday destination
for clubbing in Europe?



www.enjoy-language.se

TOURISM DISCUSSION CARDS 2

TOURISM DISCUSSION CARDS

What is included and what is not included in a holiday brochure?



www.enjoy-language.se

TOURISM DISCUSSION CARDS

How does tourism affect people living on coastlines?



www.enjoy-language.se

TOURISM DISCUSSION CARDS

What interesting jobs are there that involve travel and tourism?



www.enjoy-language.se

TOURISM DISCUSSION CARDS

What are the advantages and disadvantages of tourism ?



www.enjoy-language.se

TOURISM DISCUSSION CARDS

What is the cheapest way to travel between Germany, France and Spain?



www.enjoy-language.se

TOURISM DISCUSSION CARDS

What is the cheapest form of international travel?



www.enjoy-language.se

TOURISM DISCUSSION CARDS

Which areas of Europe are the most popular for agro-tourism?



www.enjoy-language.se

TOURISM DISCUSSION CARDS

What is agro-tourism?



www.enjoy-language.se

TOURISM DISCUSSION CARDS 3

BE CAREFUL IT MIGHT BE AGAINST THE LAW!

What is the difference between cultural tourism and heritage tourism?



www.enjoy-language.se

TOURISM DISCUSSION CARDS

Where can you go in Europe for cultural tourism?



www.enjoy-language.se

TOURISM DISCUSSION CARDS

What is cultural tourism?



www.enjoy-language.se

TOURISM DISCUSSION CARDS

What is leisure tourism?



www.enjoy-language.se

TOURISM DISCUSSION CARDS

What is activity tourism?



www.enjoy-language.se

TOURISM DISCUSSION CARDS

What are the top 5 cultural destinations in Europe?



www.enjoy-language.se

TOURISM DISCUSSION CARDS

What is the significance of heritage in tourism?



www.enjoy-language.se

TOURISM DISCUSSION CARDS

What are the advantages of adventure tourism, as well as its risks?



www.enjoy-language.se

TOURISM DISCUSSION CARDS 4

TOURISM DISCUSSION CARDS

Have you ever read an interesting article in an in-flight magazine?



www.enjoy-language.se

TOURISM DISCUSSION CARDS

What is the best place have you traveled to as an adventure tourist?



www.enjoy-language.se

TOURISM DISCUSSION CARDS

Where is the most adventurous spot in Europe for travelling?



www.enjoy-language.se

TOURISM DISCUSSION CARDS

Where is there to go hiking in Europe?



www.enjoy-language.se

TOURISM DISCUSSION CARDS

Can you list 5 leisure tourism jobs?



www.enjoy-language.se

TOURISM DISCUSSION CARDS

Can you list 5 adventure tourism jobs?



www.enjoy-language.se

TOURISM DISCUSSION CARDS

Can you list 5 cultural tourism jobs?



www.enjoy-language.se

TOURISM DISCUSSION CARDS

Can you list 5 agro-tourism jobs?



www.enjoy-language.se

TOURISM DISCUSSION CARDS 5

TOURISM DISCUSSION CARDS

Has an airline ever lost your luggage? What happened?



www.enjoy-language.se

TOURISM DISCUSSION CARDS

What are the differences between the different types of tourism?



www.enjoy-language.se

TOURISM DISCUSSION CARDS

How important is tourism to your country?



www.enjoy-language.se

TOURISM DISCUSSION CARDS

What do you think tourism will be like in the future?



www.enjoy-language.se

TOURISM DISCUSSION CARDS

What are the major tourist attractions in your country?



www.enjoy-language.se

TOURISM DISCUSSION CARDS

What is eco-tourism? Do you think it's a good idea?



www.enjoy-language.se

TOURISM DISCUSSION CARDS

Is there a difference between a tourist and a backpacker?



www.enjoy-language.se

TOURISM DISCUSSION CARDS

Do you think tourism helps people in the world understand each other?



www.enjoy-language.se

TOURISM DISCUSSION CARDS 6

TOURISM DISCUSSION CARDS

Is there a difference between
young tourists
and older tourists?



www.enjoy-language.se

TOURISM DISCUSSION CARDS

Do you think tourism is bad
for the planet?



www.enjoy-language.se

TOURISM DISCUSSION CARDS

Are you a good ambassador
for your country's
tourism industry?



www.enjoy-language.se

TOURISM DISCUSSION CARDS

What is tourism?



www.enjoy-language.se

TOURISM DISCUSSION CARDS

Could you live in another
country for the rest of
your life?



www.enjoy-language.se

TOURISM DISCUSSION CARDS

What has been your
best trip?



www.enjoy-language.se

TOURISM DISCUSSION CARDS

What has been your
worst trip?



www.enjoy-language.se

TOURISM DISCUSSION CARDS

Do you like to travel with
children?
Why or why not?



www.enjoy-language.se

TOURISM DISCUSSION CARDS 7

TOURISM DISCUSSION CARDS

When flying do you prefer a window seat or an aisle seat?



www.enjoy-language.se

TOURISM DISCUSSION CARDS

Do you prefer summer holidays or winter holidays?



www.enjoy-language.se

TOURISM DISCUSSION CARDS

Do you prefer to travel by train, bus, plane or ship?



www.enjoy-language.se

TOURISM DISCUSSION CARDS

Have you ever been in a difficult situation while traveling?



www.enjoy-language.se

TOURISM DISCUSSION CARDS

How many times have you travelled abroad?



www.enjoy-language.se

TOURISM DISCUSSION CARDS

How much luggage do you usually carry?



www.enjoy-language.se

TOURISM DISCUSSION CARDS

What countries would you most like to visit?



www.enjoy-language.se

TOURISM DISCUSSION CARDS

What do you need before you can travel to another country?



www.enjoy-language.se

TOURISM DISCUSSION CARDS 8

TOURISM DISCUSSION CARDS

What kind of customers do you find difficult?



www.enjoy-language.se

TOURISM DISCUSSION CARDS

Do you think there are many different types of tourists? Give some examples.



www.enjoy-language.se

TOURISM DISCUSSION CARDS

What kind of computer programs do you use in your work?



www.enjoy-language.se

TOURISM DISCUSSION CARDS

What are the perks of working in your industry?



www.enjoy-language.se

TOURISM DISCUSSION CARDS

Describe your place of work in detail.



www.enjoy-language.se

TOURISM DISCUSSION CARDS

Describe the positive things about your occupation.



www.enjoy-language.se

TOURISM DISCUSSION CARDS

Did you do any training for your occupation?



www.enjoy-language.se

TOURISM DISCUSSION CARDS

Name some of the tools or equipment you use.



www.enjoy-language.se

TOURISM PROFESSIONS CARDS 1

TOURISM PROFESSION CARDS

Accommodation Service Manager

Job description	Responsibilities	Skills and abilities	Future career path
<p>An accommodation service manager plans, organises, directs, controls and evaluates the operations of an accommodation establishment or a department within an accommodation establishment. They are employed by hotels, motels, resorts, bed and breakfasts etc. Accommodation service managers ensure the smooth operation of the business and should be able to work with little direction.</p>	<p>Implement and evaluate policies and procedures for the operation of the department or business Prepare budgets and monitor revenues and expenses Participate in the development of pricing and promotional strategies Negotiate with clients for the use of facilities for conventions, banquets, receptions and other functions Meet guests needs related to overnight stay and meals Recruit and supervise staff Resolve customer complaints Respond to enquiries and solve problems Ensure the completion of administrative tasks Maintain facility, equipment and supplies</p>	<p>Previous experience in tourism is preferred Strong business management skills Strong sales and marketing skills Good organisational skills Strong customer service skills Good communication skills Leadership ability Training in first aid is an asset Human resources management skills is an asset Administrative skills Diploma or degree in hotel management, hospitality, business or marketing</p>	<p>Manager of multiple departments within the business Higher level manager or executive</p>



www.enjoy-language.se

TOURISM PROFESSION CARDS

Air Traffic Controller

Job description	Responsibilities	Skills and abilities	Future career path
<p>An air traffic controller directs air traffic within assigned air space, and controls moving aircraft and service vehicles at airports. This is a busy position that requires total concentration. Traffic controllers analyse information, such as weather conditions, and load and fuel capacities, and determine strategies from this information. They monitor flights in progress and communicate with and direct pilots and ground crews. Employment is usually with the federal government or at a public, private or military airport.</p>	<p>Use radar, two-way radios and other communication Use visual tracking equipment Direct activity of moving aircraft and service vehicles on runways Issue navigational and other information to pilots Maintain radio and telephone contact with other control towers Co-ordinate movements of planes Alert emergency services when necessary Prepare and maintain flight plans, logs and other reports</p>	<p>An eye for detail Good organisational skills Good judgment and communication skills Good health, hearing and vision A willingness to continually upgrade skills A willingness to complete an Air Transport training programme A willingness to relocate Computer and technological skills and interests an asset Time management and leadership and teamwork skills an asset Emergency and disaster management skills an asset A second language an asset.</p>	<p>Flight Dispatcher Flight Service Specialist Air Traffic Control Chief Tower Controller</p>



www.enjoy-language.se

TOURISM PROFESSIONS CARDS 2

TOURISM PROFESSION CARDS

Bed and Breakfast Owner/Operator

Job description	Responsibilities	Skills and abilities	Future career path
<p>An owner/operator of a bed and breakfast, country inn, vacation farm or similar small accommodation business plans, directs and manages all the daily and long-term operations. This position offers the opportunity to work flexible hours and meet new people. Business tasks can often be combined with household tasks (e.g. breakfast for guests can be purchased at the same time as groceries for the household).</p>	<p>Meet guests' needs related to overnight stays and meals Respond to enquiries and solve problems Offer tourism information and promote local area Ensure the completion of administrative tasks Develop and maintain policies for the effective and consistent management of your staff. Promote business sales through effective marketing strategies Complete financial management tasks Maintain facility, equipment and supplies</p>	<p>Previous experience in tourism is preferred Knowledge of small business operations standards and regulations Strong business management and sales skills Good organisational skills Strong customer service and communication skills Knowledge of local business, sector and industry Leadership ability an asset Training in first aid is an asset Risk management / human resource management skills Administrative skills FOODSAFE is required Serving alcohol regulations</p>	<p>Expand business Purchase larger operation Manager/Executive in another tourism business</p>



www.enjoy-language.se

TOURISM PROFESSION CARDS

Baker

Job description	Responsibilities	Skills and abilities	Future career path
<p>Bakers prepare bread, rolls, muffins, pies, cakes and other baked goods. They may be following tried and true recipes or may be developing new ones. The position may mean the Baker specialises in creating one or two types of baked goods, or may be involved in making all the baked goods required. Bakers are also involved in ordering and maintaining supplies, and in quality and portion control.</p>	<p>Research, develop and test new recipes Prepare dough, batter and frostings Bake doughs and batters Frost and decorate baked goods Purchase baking supplies Hire and train staff Supervise production and sales Operate machinery Ensure quality of products meet established standards Draw up production schedule to determine type and quantity of goods to produce</p>	<p>Completion of secondary school is usually required Completion of a three- or four-year apprenticeship programme for bakers or Completion of a college or other programme for bakers is usually required On-the-job training is an asset For interprovincial mobility, a trade certification (Red Seal) is an asset Knowledge of National Occupational Supervisory Skills Standards is an asset</p>	<p>Head Baker Bakery Supervisor Food Production Manager Food Service Manager Owner/Operator</p>



www.enjoy-language.se

TOURISM PROFESSIONS CARDS 3

TOURISM PROFESSION CARDS

Banquet Server

Job description	Responsibilities	Skills and abilities	Future career path
<p>A banquet server serves food and beverage to patrons and provides table maintenance and room setup and tear down. Food orders may or may not have to be taken depending on the menu selections for the event. Banquet servers may work in restaurants, hotels, banquet halls or private service companies. You may adopt your own serving style, but many establishments have their own requirements such as uniform, greeting, attitude etc. This position requires excellent customer service and ability to work under pressure.</p>	<p>Greet patrons and familiarise them with the food and beverage menu May be required to present food and beverage options, take orders, make recommendations, and answer questions regarding the food and beverage Act as the point of contact between the patron and bar and kitchen staff Make recommendations on wine selection with meals Serve food and beverages May require preparation of specialty food and beverage items at the table May have to present bill and payment transaction</p>	<p>Completion of secondary school may be required Alcohol serving certification is required FOODSAFE certification is required Formal banquet servers may require completion of apprenticeship programme Customer service skills Wine expertise may be required Ability to follow instruction and abide by guidelines</p>	<p>Bartender Sommelier Restaurant Manager Food and Beverage Manager</p>



www.enjoy-language.se

TOURISM PROFESSION CARDS

Bartender

Job description	Responsibilities	Skills and abilities	Future career path
<p>Bartenders are beverage service attendants who mix and pour alcoholic and non-alcoholic beverages for guests in bars, lounges, nightclubs, restaurants, on cruise ships and at events. Depending on the establishment in which they work, bartenders may serve the drinks they make, or they may give them to a food and beverage server, who serves them to the customer. Like most tourism occupations, bartending allows you to work with people and as part of a team. Bartenders usually receive gratuities</p>	<p>Provide customer service Prepare beverages using proper bartending techniques Prepares common drinks, may also prepare drinks suggested by the patron Practice responsible alcohol service Clean and maintain bar area and wash glassware Maintain/control inventory of bar stock and supplies</p>	<p>Professional appearance and attitude Must be legal drinking age Customer service skills are required Cash handling experience Ability to multi-task Knowledge of relevant laws and regulations Product knowledge A secondary school diploma is preferred Courses in bartending are an asset Serving alcohol regulations are required Safe food handling is required where applicable First aid is an asset National Occupational Certification as a Bartender is an asset</p>	<p>Head Bartender Food and Beverage Service Supervisor Beverage Services Manager Assistant Manager Manager Owner/Operator</p>



www.enjoy-language.se

TOURISM PROFESSIONS CARDS 4

TOURISM PROFESSION CARDS

Campground Operator

Job description	Responsibilities	Skills and abilities	Future career path
<p>Campground Operators manage all aspects of private or public campgrounds in a safe and professional manner. The duties of a Campground Operator are diverse, requiring both people and mechanical skills. Much of the work is outdoors and the seasonal nature of most campgrounds generally allows for different opportunities during the off season. Some operators take the winter off, some have a different winter career, and still others continue to operate their campgrounds throughout the winter season.</p>	<p>Offer tourism information and promote local area Maintain and repair facility, equipment and supplies Respond to enquiries and solve problems Oversee operation of retail outlets Manage human resource functions, such as hiring and training staff Use business management skills Use sales and marketing skills Complete financial management tasks, such as managing payroll and cash flow Use administrative skills</p>	<p>Experience in tourism is an asset Knowledge or previous experience in physical plant maintenance and of campground operations is an asset. Customer service skills are required Knowledge of the local area, region and tourism industry are generally requirements Marketing, promotional, HR management skills Financial management skills Good communication skills Risk management skills and organisational skills are an asset First aid is a requirement Cardiopulmonary resuscitation (CPR) is a requirement</p>	<p>Manager of Chain Resort Manager</p>



www.enjoy-language.se

TOURISM PROFESSION CARDS

Casino Dealer

Job description	Responsibilities	Skills and abilities	Future career path
<p>Casino Dealers conduct games in casinos and casino hotels. They deal cards and may handle large amounts of money. They may work evenings, weekends and holidays, as casinos are often busiest after 9-5 working hours. They may receive gratuities in addition to salary.</p>	<p>Operate gambling tables and games such as blackjack, roulette, keno, baccarat, etc. Ensure the rules of the game and house are being followed Determine winners, pay out winning bets and collect losing bets</p>	<p>Basic mathematical skills Manual dexterity is required Good customer service skills Good communication skills Cash handling experience is a requirement Knowledge of various casino games is a requirement A secondary school diploma is preferred Knowledge of the National Occupational Entry Level Skills Standards is an asset</p>	<p>Supervisor Assistant Manager Games Manager Manager</p>



www.enjoy-language.se

TOURISM PROFESSIONS CARDS 5

TOURISM PROFESSION CARDS

Casino Slot Attendant

Job description	Responsibilities	Skills and abilities	Future career path
<p>A casino slot attendants provides a variety of guest services on the gaming floor. The range and extent of skills used in the workplace depends upon the jurisdiction, the casino and the available technology. They may work evenings, weekends and holidays, as casinos are often busiest after 9 - 5 working hours. They may receive gratuities in addition to salary.</p>	<p>Handle cash Explain games Maintain machines and gaming area</p>	<p>Good communication skills Good customer service skills Mathematical skills Professional appearance and attitude Cash handling experience Time management skills Knowledge of relevant laws and regulations Knowledge of the machines, facility, industry group and of the tourism sector Legal gambling age is a must A secondary school diploma is preferred Training in customer service an asset Provincial casino gaming license a must</p>	<p>Shift Supervisor Assistant Manager Manager</p>



www.enjoy-language.se

TOURISM PROFESSION CARDS

Catering Manager

Job description	Responsibilities	Skills and abilities	Future career path
<p>Catering managers oversee all aspects of catering services in hotels, resorts, private clubs and events and conferences. The catering manager develops, implements and monitors standards of service and coordinates catering activities amongst staff to ensure that a high quality of production and service is consistently maintained. The catering manager may also develop and administer budgets control costs and assist with sales and marketing.</p>	<p>Plan, coordinate and supervise the activities of workers in dining rooms, kitchens, bars and other areas Keep records of payment and expense Assist in promotion and sales Conduct regular inspections of operation Resolve customer complaints Manage human resources, such as recruitment, hiring, training and scheduling Consult with clients, providing plans and cost estimates Maintain contact with clients before, during and after event to ensure satisfaction</p>	<p>Proven supervisory or management experience is required Food and beverage experience is an asset Customer service and communication skills an asset Planning and budgeting experience is an asset Business management skills and time management skills are an asset A diploma or degree in hospitality or food and beverage management is generally required Knowledge of alcoholic and non-alcoholic beverages Safe food handling First aid and service training are assets Alcohol regulations</p>	<p>Nightclub Manager Beverage Services Manager Food and Beverage Director General Manager Owner/Operator</p>



www.enjoy-language.se

TOURISM PROFESSIONS CARDS 6

TOURISM PROFESSION CARDS

Chief Concierge

Job description	Responsibilities	Skills and abilities	Future career path
<p>A chief concierge supervises both guest services attendants and concierges. A concierge serves the needs of guests in hotels, resorts and other accommodation facilities by providing information and special services to enhance guests' visits. The position is varied: a concierge may be asked to book elusive theatre tickets, give directions to a local festival or recommend a doctor.</p>	<p>Supervise and direct guest services attendants and concierges Communicate directly with guests, in person or by telephone Provide information on facilities and services, events and attractions, tours, travel routes and transportation schedules Provide area maps, brochures and other literature Arrange tickets, bookings, appointments and reservations for guests</p>	<p>A secondary school diploma is required Post-secondary training in tourism or hospitality management is an asset Good communication skills and customer service skills are required A strong knowledge of the community, area and region is necessary Guest services or concierge experience is necessary Problem solving, organization and time management, and supervision skills A second language is an asset</p>	<p>Assistant Front Office Manager Ship's Purser Front Office Manager Sales Manager General Manager</p>



www.enjoy-language.se

TOURISM PROFESSION CARDS

Cook

Job description	Responsibilities	Skills and abilities	Future career path
<p>Cooks prepare and cook a wide variety of food. Cooks may be responsible for basic food preparation like salads and sandwiches to more complex tasks like roasting and pattes. They are employed in restaurants, cafeterias and hotels. Cooks are also employed aboard ships and logging campsites. Dependant on the size of the kitchen, cooks may have exposure to several responsibilities or only to specific tasks.</p>	<p>Basic food preparation Prepare and cook individual dishes or entire meals Ensure sanitary cooking conditions and appropriate safe food handling May have to monitor or guide kitchen staff May assist in menu development May assist in cost control, monitoring and ordering of supplies</p>	<p>A secondary school diploma is usually required Related post secondary school courses are preferred Registration in an apprenticeship programme is an asset Basic food preparation Rethermalization of prepared foods Developing knowledge of butchery and fish cutting Developing knowledge of baking and pasty production Developing knowledge of all cooking methods such as roasting, stewing etc. Ability to deal with high pressure environments Knowledge of food safety (e.g. FOODSAFE certification) is recommended</p>	<p>3rd Cook 2nd Cook 1st Cook Chef de Partie Sous Chef Executive Chef</p>



www.enjoy-language.se

TOURISM PROFESSIONS CARDS 7

TOURISM PROFESSION CARDS

Customer Service Director

Job description	Responsibilities	Skills and abilities	Future career path
<p>A customer service director plans, organises, directs and controls the operations of a customer service area of a transportation company. They oversee customer service representatives as well as perform the duties of a customer service representative when required. They may be employed at an airport, rail station or a cruise or ferry service counter.</p>	<p>Manage human resource functions, such as assigning staff duties Respond to customer enquiries or complaints Attend to comfort and concerns of passengers Make and change reservations Receive payment and process forms Supervise facility operation Communicate with other departments as needed Use administrative skills</p>	<p>Customer service experience Supervisory or management experience Good judgment and problem-solving skills Strong communication skills Strong leadership and team-building skills Time management skills an asset Financial management skills an asset A second language an asset Secondary school diploma is required Degree or diploma in business, marketing or tourism is often necessary Knowledge of the National Occupational Supervisory Skills Standards is an asset.</p>	<p>Marketing and Sales Manager Assistant Manager General Manager of Operations</p>



www.enjoy-language.se

TOURISM PROFESSION CARDS

Daycare Employee - Ski Resort

Job description	Responsibilities	Skills and abilities	Future career path
<p>The role of the daycare employee is to provide a safe environment for children to play in. Unlike other daycares, the daycare facility at a ski resort has the added bonus of children being able to enjoy the snow and related activities from an early age.</p>	<p>Supervise the children's play in the daycare Help to plan, set up, and lead children's daily activities Ensure that all guests are being attended to in the appropriate manner Adhere to operating policies as outlined in Social Services and Daycare Employee Manual Adhere to sanitary demands of the daycare Light cleaning duties Supervise the magic carpet ski lift Administration, checking in and out of children</p>	<p>Friendly personality with the ability to relate to children Ability to work in a team-oriented environment Demonstrated childcare experience First-aid training including CPR</p>	<p>Guest services management</p>



www.enjoy-language.se

TOURISM PROFESSIONS CARDS 8

TOURISM PROFESSION CARDS

Director of Golf

Job description	Responsibilities	Skills and abilities	Future career path
<p>A director of golf manages, supervises and oversees the entire golf operation in order to maintain the highest standards of excellence for guests and members. They work closely with all department heads and maintain superior relationships with guests, members and suppliers.</p>	<p>Design, promote and direct all golf activities Prepare budgets for golf operations Order merchandise for golf shop Order supplies associated with golf activities Maintain attractive, orderly appearance in pro shop Supervise staff Organise charges and collect fees for all golf-related activities Conduct golf clinic and training programmes Market and organise all public and club tournaments Interpret and enforce golf rules and regulations</p>	<p>Knowledge of marketing and financial management Time management, problem solving and decision making skills Supervisory experience Good communication and interpersonal skills Customer service experience Organisational and time management skills Experience and knowledge of golf course operation Expert knowledge of golf and rules and regulations Knowledge of WHMIS and OHS)practices First Aid and CPR certification an asset Experience in golf instructions</p>	<p>General Manager Golf Club Owner</p>



www.enjoy-language.se

TOURISM PROFESSION CARDS

Director of Sales and Marketing

Job description	Responsibilities	Skills and abilities	Future career path
<p>Sales and marketing directors are responsible for establishing and directing the marketing and sales activities of an organisation including advertising and public relations. These activities affect the direction and goals of business. The position could be available in any one of the five business sectors of tourism.</p>	<p>Assign sales territory, target groups and sales quotas Coordinate sales activities Prepare and submit plans, budgets, progress reports and annual sales reports Manage human resource functions Research competitors' products/services Develop goals and objectives, projects and priorities and assign them to Sales Managers Develop and conduct sales campaigns, as well as marketing and promotional plans</p>	<p>A university degree or college diploma in business administration, marketing, communications, public relations, advertising or a related field is required Previous supervisory or management experience in sales, marketing, public relations and/or the tourism industry is required Knowledge of the product and competitive environment is required Proof of previous sales success Strong network of connections is an asset Leadership skills Excellent communication and HR management skills Financial management skills</p>	<p>Assistant Manager Executive Manager General Manager Vice President of Sales and Marketing</p>



www.enjoy-language.se

TOURISM PROFESSIONS CARDS 9

TOURISM PROFESSION CARDS

Executive Chef

Job description	Responsibilities	Skills and abilities	Future career path
<p>Executive chefs oversee all kitchen staff, food preparation and cooking activities in a facility or for several restaurants in an establishment or chain. Most of their time is spent outside of the kitchen researching and responding to trends in the food industry, planning and writing menus, budgeting and financial planning, and participating in business development. Recruits and hires staff, supervises their activities and instructs cooks in preparation, cooking, garnishing and presentation of food.</p>	<p>Plan and develop menus using descriptive text to encourage sales Industry trend analysis Ensure food meets quality standards Use financial management skills for budgetary and cost control purposes Use human resource management skills for recruitment, training and scheduling May be responsible for capital expenditures May prepare and cook meals and specialty foods</p>	<p>Red Seal, Certified Chef de Cuisine designation or Culinary Arts Diploma is required A secondary school diploma Knowledge of FOODSAFE, workplace hazardous materials and first aid is generally required Must have proven experience as a Chef, Cook, Catering Manager or equivalent Human resource management skills are required; recruitment, selection, training, performance management etc. Financial management skills Good communication and leadership skills Time management and analytical skills</p>	<p>Food and Beverage Manager Corporate Chef Owner/Operator</p>



www.enjoy-language.se

TOURISM PROFESSION CARDS

Executive Housekeeper

Job description	Responsibilities	Skills and abilities	Future career path
<p>Executive housekeepers direct and control housekeeping operations and staff of the housekeeping department. An executive housekeeper, co-ordinates between housekeeping crews to inspect assigned areas to ensure standards are met. An executive housekeeper manages many priorities and demands and is able to solve problems, support staff, as well as perform the duties of a housekeeper when required.</p>	<p>Establish and/or implement operating procedures and standards Plan and coordinate the activities of housekeeping supervisors and their crew Coordinate inspection or inspect assigned areas to ensure standards are met Apply human resource management skills, such as hiring, training, scheduling and evaluating performance Complete financial management tasks, such as setting and adhering to a budget Handle administrative tasks</p>	<p>A secondary school diploma is an asset A college diploma in tourism or business management is an asset, as is National Occupational Certification as a Housekeeping Room Attendant Professional attitude Previous experience working in housekeeping is required Previous supervisor or manager experience is an asset Human resource management skills such as recruitment and training Basic accounting skills Good customer service skills Purchasing and inventory skills is an asset</p>	<p>Front Office/Rooms Division Manager Housekeeping Director Rooms Division Executive</p>



www.enjoy-language.se

TOURISM PROFESSIONS CARDS 10

TOURISM PROFESSION CARDS

Ferry Boat Captain

Job description	Responsibilities	Skills and abilities	Future career path
<p>A ferry boat captain operates ferries, transporting passengers and cargo on a set path between two or more docks in coastal and inland waters. They maintain a schedule, oversee loading and unloading procedures on the ship and supervise and co-ordinate the activities of deck crews. Employment could be through a marine transport company or the federal government.</p>	<p>Command and operate ferry boats Determine geographic positioning Execute safe navigational passage Maintain navigational instruments and equipment Direct activity of deck crew Direct and supervise loading and unloading of vehicles and foot passengers Be prepared to handle emergency situations Keep ship's log monitor other vessels along route</p>	<p>Concentration and focus Technical aptitude Good judgment and problem-solving skills Good communication skills Leadership qualities An ability to work as an effective team member Good health, hearing and vision Proven navigational skills Time management skills Emergency/disaster management skills. One to three year's experience on a deck crew.</p>	<p>Ferry Boat Master Ship's Captain Owner/Operator of a marine transport company</p>



www.enjoy-language.se

TOURISM PROFESSION CARDS

Food & Beverage Service Supervisor

Job description	Responsibilities	Skills and abilities	Future career path
<p>Food and beverage managers plan, organise, direct, control and evaluate the operations of restaurants, bars, cafeterias and other businesses that operate serving food and beverage. Food and beverage managers may be employed by restaurants, bars, hotels and resorts etc. Food and beverage managers still require great customer skills but apply management skills ensuring the labour and financial goals of the organisation are maintained.</p>	<p>Organise, direct and evaluate food and beverage service Recruitment and training of staff Shift scheduling Performance management; monitor staff performance and provide feedback Purchase and control of inventory Monitor revenues and expenses Ensure practice of health and safety regulations Negotiate supplier arrangements for food and beverage products Negotiate with clients for use of facilities for catering, parties, banquets, etc.</p>	<p>Completion of secondary school should be required Diploma or degree in business management or tourism related field would be an asset Leadership skills Flexibility Adaptability Inventory management Conflict resolution Ability to work under pressure Ability to multi-task Good organisational skills</p>	<p>Director of Sales and Marketing General Manager</p>



www.enjoy-language.se

TOURISM PROFESSIONS CARDS 11

TOURISM PROFESSION CARDS

Accommodation Service Manager

Job description	Responsibilities	Skills and abilities	Future career path
Plans, organises, directs, controls and evaluates the operations of an accommodation establishment or of a department within an accommodation establishment Employed by hotels, motels, resorts, bed and breakfasts etc. Ensure the smooth operation of the business Should be able to work with little direction	Plans, organises, directs, controls and evaluates the operations of an accommodation establishment Employed by hotels, motels, resorts, bed and breakfasts etc. Ensure the smooth operation of the business Should be able to implement and evaluate policies and procedures for the operation of the department or business Prepare budgets and monitor revenues and expenses	Previous experience in tourism is preferred Strong business management skills Strong sales and marketing skills Good organisational skills strong customer service skills Good communication skills leadership ability training in first aid is an asset Human resources management skills is an asset administrative skills Diploma or degree in hotel management, hospitality, business or marketing	Manager of multiple departments within the business Higher level manager or executive



www.enjoy-language.se

TOURISM PROFESSION CARDS

Food Service Counter Attendant

Job description	Responsibilities	Skills and abilities	Future career path
A food service counter attendant prepares, heats and finishes simple food items. These simple food items are served to customers at food counters. Food service counter attendants are employed in food and beverage establishments where servers are not used or the dining experience is more casual, buffet or fast food in style.	Take orders from patrons Prepare foods like sandwiches, burgers, wraps, salads, soft drinks etc. Basic plate and portion preparation; both dine-in and take-out Serve customers at counter or buffet style setting Stock inventory May handle cash and cash count in till	Secondary school education is usually required Good communication skills Good customer service skills Cash handling skills	Team Lead Manager



www.enjoy-language.se

TOURISM PROFESSIONS CARDS 12

TOURISM PROFESSION CARDS

Freshwater Angling Guide

Job description	Responsibilities	Skills and abilities	Future career path
<p>A freshwater angling guide is an outdoor adventure guide who organises and conducts fishing expeditions. They can either operate their own small businesses or work for adventure tourism companies, resorts, parks, lodges or campgrounds. They might take clients for a day trip or for longer expeditions.</p>	<p>Guide clients to designated areas Create positive client relations Assemble necessary equipment and supplies Set up and break camp Prepare and/or serve meals Instruct and demonstrate fishing skills and techniques Respect and maintain environment</p>	<p>Fishing experience and knowledge Knowledge of the terrain, environment and local area in which the guide is to travel and fish Physical ability and ability to get along and work well with others Organisational and leadership skills Excellent communication and instruction skills Knowledge of outdoor cooking skills is desired Equipment maintenance and repair skills Knowledge of relevant laws, safety and emergency procedures Standard first aid and CPR are usually required.</p>	<p>Supervisor Manager Owner/Operator of small business</p>



www.enjoy-language.se

TOURISM PROFESSION CARDS

Front Desk Agent

Job description	Responsibilities	Skills and abilities	Future career path
<p>Often a guest's first impression of a property is the result of the Front Desk Agent's skills and abilities. Front desk agents provide many guest services, working in the lobby or reception areas of hotels, motels, resorts and other accommodation facilities. The position is challenging, varied and offers the opportunity to work flexible hours and meet many new people.</p>	<p>Assist guests with arrivals and departures Handle guests' concerns Offer referral for services and handle requests for information Handle and store luggage Assist with the check-in and check-out of groups and tours Provide valet parking Assist other departments as required</p>	<p>A secondary school diploma is required Post-secondary training in tourism or hotel management is an asset Excellent communication and organisation skills Professional attitude Previous experience in customer service is an asset Ability to use a variety of computer applications Cash handling experience is an asset Administrative skills Time management skills Ability to speak a second language is an asset Working knowledge of the facility, services and local area</p>	<p>Front Concierge Assistant Front Office Manager Front Office Manager Customer Service Agent Flight or Ship Attendant Supervisor</p>



www.enjoy-language.se

TOURISM PROFESSIONS CARDS 13

TOURISM PROFESSION CARDS

Fundraising Consultant

Job description	Responsibilities	Skills and abilities	Future career path
<p>Fundraising Consultants coordinate the fundraising activities for an event, conference or non-profit organisation. They request support from businesses and individuals, and are required to explain what raised funds will be used for when asked. This can be a very creative position, as there are many ways to raise funds.</p>	<p>Solicit corporate, government and foundation support via presentations, proposals, etc. Solicit public donations via direct mail campaigns and donor programmes Establish and operate endowments, bequests and deferred-giving programmes Conduct membership drives and fundraising campaigns Raise funds and awareness through special events Write and produce promotional material Publicise organisation and events Thank sponsors or organise sponsor appreciation programmes</p>	<p>A secondary school diploma is required A degree or diploma in business, arts administration, marketing or communications is an asset Previous fundraising experience is an asset Strong communication skills Marketing skills Proven experience in budgeting and managing money Strong organisational skills</p>	<p>Executive Director Owner/Operator</p>



www.enjoy-language.se

TOURISM PROFESSION CARDS

Games Manager

Job description	Responsibilities	Skills and abilities	Future career path
<p>A games manager is responsible for the gaming functions at casino operations. They oversee dealers and supervisors, and provide supervision, training and support. Games managers must demonstrate leadership and be able to make responsible decisions.</p>	<p>Develop and administer policies and procedures Handle day-to-day casino operations Oversee gaming tables Supervise personnel, e.g. ensure policies are adhered to assure the security and protection of the cash</p>	<p>Dealer or gaming supervisor experience Customer service skills Problem solving skills Communication skills Management or supervisory experience Human resource management skills desired Time management skills desired Monetary transaction skills desired Secondary school diploma Knowledge of the National Occupational Supervisory Skills Standards is an asset</p>	<p>Casino General Manager Owner/Operator</p>



www.enjoy-language.se

TOURISM PROFESSIONS CARDS 14

TOURISM PROFESSION CARDS

Gate/Cash Attendant

Job description	Responsibilities	Skills and abilities	Future career path
<p>A gate/cash attendant identifies to customers the price of admission to an attraction or the cost of related goods and services. They receive and process payment, provide tickets or proof of purchase, answer questions and provide directions. Work may be at any type of attraction, ranging from museums and art galleries to historic sites and botanical gardens.</p>	<p>Follow established cash-handling procedures Share knowledge of attraction with customers Handle customer comments, complaints and requests Cash out and reconcile cash with total sales</p>	<p>Good communication skills Professional attitude Organisational skills Enjoy working with people Cash handling experience Knowledge of the attraction and local area Customer service experience is desirable. Secondary school diploma is preferred. Knowledge of the National Occupational Entry Level Skills Standards is an asset.</p>	<p>Attraction Tour Guide Attraction Supervisor</p>



www.enjoy-language.se

TOURISM PROFESSION CARDS

General Manager

Job description	Responsibilities	Skills and abilities	Future career path
<p>The general manager is the most senior executive of a tourism business; although, they might report to the owner or executive of the establishment. A general manager is responsible for operational, marketing, human resources and other business planning. They develop the budget for each department, approve expenses and establish the standards of service. The general manager also has responsibility for departmental meetings, supplier relations and overall maintenance of the establishment.</p>	<p>Plans and directs the operations and departments Establishes the financial and service standards of the organisation Prepares budgets Monitors expenses Schedules/supervises staff</p>	<p>A college diploma or university degree in business management or a related field Several years of experience is required; this experience may replace the requirement of some formal education Leadership skills Entrepreneurship skills Communication skills Financial planning and budgeting experience is an asset Business management skills is an asset Time management skills</p>	<p>Executive Owner/Operator</p>



www.enjoy-language.se

TOURISM PROFESSIONS CARDS 15

TOURISM PROFESSION CARDS

Maintenance Mechanic

Golf Course

Job description	Responsibilities	Skills and abilities	Future career path
A golf course maintenance mechanic stores, maintains and distributes golf carts.	Clean carts and charge batteries and maintain and repair golf carts Maintain sufficient inventory of parts and tools to support a quality cart repair and maintenance programme Organise strictly scheduled preventive maintenance programme for all carts Submit charges to Book-keeper or Golf Professional for all services rendered to members Maintain cart shop and adjacent areas in a clean and orderly manner Operate golf carts and cart shop equipment in a safe and professional manner Provide carts to Starter when required	Diploma or certificate as a electrical mechanic or equivalent trade as a mechanic Knowledge of equipment repairing and troubleshooting Experience and knowledge of golf course operation Knowledge of Workplace Hazardous Materials Information System (WHMIS) Positive attitude and willingness to work in a team Good communication skills Enthusiasm for golf an asset Welding and fabrication experience an asset Valid driver's license	Cart Shop Manager Equipment Maintenance Supervisor Head Professional General Manager



www.enjoy-language.se

TOURISM PROFESSION CARDS

Golf Club Manager

Job description	Responsibilities	Skills and abilities	Future career path
Golf Club General Managers are senior executives who report to an owner or board of directors on all management functions. This includes operating procedures, practices and financial results of a golf club.	Offer tourism information and promote local area Oversee golf shop operations Complete financial management tasks, such as development of a budget and managing the payroll Oversee office operations Oversee operation of retail and food and beverage outlets Manage human resource functions, such as recruitment, training and disciplining of staff Oversee turf management, maintenance and facility repair operations Recruit and retain golf club members	A secondary school diploma is required Degree or diploma in business, tourism or recreation is an asset Previous management experience is required Knowledge of golf and golf club operations is required Excellent customer service skills Knowledge of turf grass management is necessary Financial management and HR management skills Operations management skills Sales and marketing skills Excellent communication and organisational skills Knowledge of food and beverage and retail operations is an asset	Manager of chain of clubs Owner Resort Manager



www.enjoy-language.se

TOURISM PROFESSIONS CARDS 16

TOURISM PROFESSION CARDS

Golf Course Assistant Professional

Job description	Responsibilities	Skills and abilities	Future career path
An assistant golf professional oversees all aspects of merchandise in the golf shop, which includes ordering, receiving, pricing, sales, storing and display of merchandise, as well as provides all documentation, inventory and control reports as required. They also assist the Head Professional in providing guests with a pleasant golf experience.	<p>Assist golf professional in instructing and managing merchandising and on-course personnel</p> <p>Oversee and perform daily operations of the golf shop</p> <p>Promote the game of golf and assist all players by providing and interpreting etiquette, policies, rules and regulations</p> <p>Conduct golf clinics</p> <p>Assist Head Professional in determining marketing objectives</p> <p>Attend professional, committee and staff meetings as required</p> <p>Promote member participation in all golf club events</p> <p>Interact with golf club members</p>	<p>Knowledge of marketing and financial management</p> <p>Problem solving and decision making skills</p> <p>Member in good standing with the CPGA</p> <p>Teaching and Coaching Certification from the CPGA</p> <p>Supervisory experience</p> <p>Good communication skills</p> <p>Organisational and time management skills</p> <p>Experience and knowledge of golf course operation</p> <p>Expert knowledge of golf and rules and regulations</p> <p>Knowledge of WHMIS and OHS practices</p> <p>First Aid and CPR certification an asset</p> <p>Experience in golf instructions</p>	<p>Head Professional</p> <p>General Manager</p> <p>Golf Course Owner</p>



www.enjoy-language.se

TOURISM PROFESSION CARDS

Golf Course Assistant Superintendent

Job description	Responsibilities	Skills and abilities	Future career path
A golf course assistant superintendent assists the golf course superintendent in maintaining the aesthetics of the golf course. They are also responsible for staff scheduling and training, overseeing fertility and pesticide programmes, ensuring proper operation of the irrigation system as well as participating in all ongoing projects on the golf course.	<p>Plan and supervise the maintenance of the golf course</p> <p>Organise and delegate work schedules as well as project work</p> <p>Supervise, manage and train turf maintenance staff</p> <p>Report to the superintendent on all department activities</p> <p>Develop and implement employee safety policy</p> <p>Assist with cultural practices and proper operations of the irrigation system</p> <p>Respond to internal and external customer inquiries</p> <p>Perform other duties as required by the superintendent</p>	<p>A degree or diploma in turf management</p> <p>Golf course maintenance experience</p> <p>Supervisory and/or foreman experience</p> <p>Knowledge of irrigation operation and water management and of golf course equipment, maintenance and repairs</p> <p>Experience and knowledge of golf course operation</p> <p>Excellent leadership skills and trouble shooting skills</p> <p>Experience in supervising, directing, scheduling staff</p> <p>Knowledge of computer programmes</p> <p>Knowledge of fertility and application methods</p> <p>Driver's license</p>	<p>Superintendent</p> <p>Golf Course General Manager</p>



www.enjoy-language.se

TOURISM PROFESSIONS CARDS 17

TOURISM PROFESSION CARDS

Golf Course Equipment Technician

Job description	Responsibilities	Skills and abilities	Future career path
<p>A golf course foreman reports directly to the golf course superintendent. They are responsible for assisting in the daily management and operations of the golf course and overseeing the weekend maintenance operations. Other responsibilities include training and supervision of staff as well as assisting in all aspects of cultural practices, proper operation of the irrigation system as well as operation of equipment.</p>	<p>Coordinate scheduling of turf maintenance staff to meet workload and safety requirements Maintain and oversee work unit budgets Assist in recruiting and mentoring turf maintenance staff Train staff on monitoring, maintenance and servicing of equipment to ensure operational standards Respond to internal and external customer inquiries Perform other duties as required by the superintendent</p>	<p>A degree in horticulture, grounds or landscaping or a diploma combined with operational experience Golf course maintenance experience Supervisory experience Ability to supervise and train staff on proper use of maintenance equipment Knowledge of WHMIS and OHS practices Excellent communication, interpersonal and organizational skills Experience and knowledge of golf course operation First Aid and CPR certification an asset Experience with driving tractor or mowing equipment an asset Driver's license</p>	<p>Golf Club General Manager Assistant Superintendent Superintendent</p>



www.enjoy-language.se

TOURISM PROFESSION CARDS

Golf Course Foreman

Job description	Responsibilities	Skills and abilities	Future career path
<p>A golf course foreman reports directly to the golf course superintendent. They are responsible for assisting in the daily management and operations of the golf course and overseeing the weekend maintenance operations. Other responsibilities include training and supervision of staff as well as assisting in all aspects of cultural practices, proper operation of the irrigation system as well as operation of equipment.</p>	<p>Coordinate scheduling of turf maintenance staff to meet workload and safety requirements Maintain and oversee work unit budgets Assist in recruiting and mentoring turf maintenance staff Train staff on monitoring, maintenance and servicing of equipment to ensure operational standards Respond to internal and external customer inquiries Perform other duties as required by the superintendent</p>	<p>A degree in horticulture, grounds or landscaping or a diploma combined with operational experience A minimum of two to three years of golf course maintenance experience A minimum of two years of supervisory experience Ability to work independently and collectively as a team Ability to supervise and train staff on proper use of maintenance equipment Knowledge of Workplace Hazardous Materials Information System (WHMIS) and Operational Health and Safety (OHS) practices Excellent communication, interpersonal and organizational skills Good time management skills Experience and knowledge of golf course operation Knowledge of computer programs First Aid and CPR certification an asset Experience with driving tractor or mowing equipment an asset Valid driver's license</p>	<p>Golf Club General Manager Assistant Superintendent Superintendent</p>



www.enjoy-language.se

TOURISM PROFESSIONS CARDS 18

TOURISM PROFESSION CARDS

Golf Course Irrigation Technician

Job description	Responsibilities	Skills and abilities	Future career path
An irrigation technician is responsible for maintaining proper irrigation on all grounds.	<ul style="list-style-type: none"> Designs, implements and maintains mechanical and electrical components of complex irrigation system Repairs equipment associated with irrigation Performs preventive maintenance on all equipment associated with irrigation Trains and supervises staff assigned to irrigation responsibilities Controls expenses associated with irrigation equipment and activities Maintains inventory of parts needed for irrigation equipment Irrigates all grounds as needed 	<ul style="list-style-type: none"> Diploma or certificate in turf management Organisational and time management skills Experience and knowledge of irrigation system management Experience and knowledge of irrigation equipment repairing and troubleshooting Knowledge of Workplace Hazardous Materials Information System (WHMIS) Good communication skills Enthusiasm for golf an asset Welding and fabrication experience an asset Pesticide Applicator certification an asset Valid driver's license 	<ul style="list-style-type: none"> Golf Course Equipment Technician Equipment Maintenance Supervisor Superintendent



www.enjoy-language.se

TOURISM PROFESSION CARDS

Golf Course Marshall

Job description	Responsibilities	Skills and abilities	Future career path
A golf course marshall ensures smooth pace of play on golf course, and acts as an information centre for golf and real estate development issues.	<ul style="list-style-type: none"> Observe pace of play Request slower playing groups to speed up pace or to allow others to play through, if appropriate Escort unauthorized people from course Ensure that divots and ball marks are repaired Report all infractions to Starter Ensure that sand traps are raked Carry and provide clean towels and water for ball washers Assist Starter at first tee during busy times 	<ul style="list-style-type: none"> Good communication skills Good interpersonal skills Organisational skills Customer service experience Positive attitude and willingness to work in a team Knowledge of the game of golf 	<ul style="list-style-type: none"> Starter Head Professional General Manager



www.enjoy-language.se

TOURISM PROFESSIONS CARDS 19

TOURISM PROFESSION CARDS

Groomer

Job description	Responsibilities	Skills and abilities	Future career path
<p>Groomers are the people who spend their nights farming all the snow, laying down corduroy for the following days' sliders. They also spend their time taming new snowfalls, rebuilding ski runs, building terrain features for terrain parks and generally creating an awesome skiing/boarding experience for guests.</p>	<p>Create high quality sliding conditions Keep buildings, lift terminals and so on, clear of hazards and snow Perform pre start up inspections per established checklists Perform shut down and post operational procedures including documentation regarding machine maintenance Observe carefully and adhere to all company safety, operating and maintenance procedures Maintain a good working relationship with all staff and assist other departments as required Have an eye for risk management issues</p>	<p>Mountain operations experience and/or heavy equipment operating experience Mechanically inclined Valid drivers license Self-motivated, responsible and open minded Able to work alone or with others Able to work shift work and unsociable hours Physically healthy and good skier or boarder</p>	<p>Heavy equipment operator Apprentice mechanic Slopes Supervisor Slopes Manager Mountain Operations Manager General Manager</p>



www.enjoy-language.se

TOURISM PROFESSION CARDS

Guest Services Attendant

Job description	Responsibilities	Skills and abilities	Future career path
<p>A guest services attendant provides service to guests at the main door or lobby of an accommodation property. They help with luggage, offer information, and generally endeavor to make each and every person's stay a pleasant one. Work can be very fast-paced, especially during the high season, but extra effort may be rewarded with gratuities. Guest services attendants are often the eyes and ears of a property, as they are constantly moving around it, and often notice issues that need attending to.</p>	<p>Provide guests with verbal or written information about the facilities, services, room choices and rates, and area attractions Make room reservations following established procedures, using computerised or manual systems Handle guest arrivals and departures Handle guest keys, mail and faxes Compile record sheets or log books, guest accounts and vouchers Prepare bills and process payments</p>	<p>Professional attitude Ability to work as a member of a team Good communication skills Customer service skills Enjoy working with people Physical ability to lift and carry heavy suitcases and other items Good time management skills may be required Knowledge of facility, services and locale Secondary school diploma is preferred Post-secondary training in tourism is advantageous Guest Services Attendant National Occupational Certification is an asset.</p>	<p>Concierge Train Service Attendant Passenger Attendant Guest Services Manager Assistant Front Desk Manager Front Desk Manager</p>



www.enjoy-language.se

TOURISM PROFESSIONS CARDS 20

TOURISM PROFESSION CARDS

Heritage Interpreter

Job description	Responsibilities	Skills and abilities	Future career path
<p>Heritage interpreters help others understand and appreciate cultural or natural heritage. They work in many different settings - from parks, museums and aquariums to industrial sites, interpretive centres and botanical gardens. Interpreters do not simply lecture - they have a complete understanding of their subject matter and share their interest and knowledge with others. The different audiences make this position interesting and stimulating.</p>	<p>Develop and deliver educational or cultural programmes Operate presentation equipment (e.g. audiovisual, overheads, slide shows, etc.) Protect resources</p>	<p>A secondary school diploma is required A related degree in tourism/ecotourism is an asset Adapt to different learning styles and participant needs Excellent communication and public speaking skills Ability to research Previous customer service experience an asset Interpretive experience may be required Leadership skills Problem-solving skills Working knowledge of the area, its heritage and other relevant information Working knowledge of basic computer applications First aid training and other safety training is an asset</p>	<p>Supervisor of Interpretive Services Assistant Manager/Manager of Interpretive Services Curator</p>



www.enjoy-language.se

TOURISM PROFESSION CARDS

Housekeeping Room Attendant

Job description	Responsibilities	Skills and abilities	Future career path
<p>Housekeeping room attendants provide for the comfort of guests in hotels, motels, resorts, lodges and inns by ensuring that guest rooms and public areas are clean and properly presented. A housekeeping room attendant promotes a positive image of the property to guests, and must be pleasant, friendly and able to address problems or special requests.</p>	<p>Stock and sort supplies Vacuum, clean, dust and polish guest rooms Make beds, change sheets, remove and replace used towels and toiletries Deliver and retrieve items on loan to guests e.g. iron and ironing boards Ensure security of guest rooms and privacy of guests Perform rotation cleaning duties (e.g. steam clean carpets) as required</p>	<p>A secondary school diploma is preferred Physical mobility and stamina required Ability to follow instruction Detail-oriented Professional attitude is required Ability to work independently Excellent time management skills Bondable is generally required Previous customer service experience may be required Good communication skills are an asset Good organisational skills Workplace Hazardous Materials Information System (WHMIS) is an asset</p>	<p>Assistant or Executive Housekeeper Laundry Supervisor Aircraft Groomer</p>



www.enjoy-language.se

TOURISM PROFESSIONS CARDS 21

TOURISM PROFESSION CARDS

Hunting Guide

Job description	Responsibilities	Skills and abilities	Future career path
<p>A hunting guide organises and conducts expeditions for hunters. They work for adventure tourism companies or they open their own private operations. Trips may be a day long, or they may take clients on longer expeditions.</p>	<p>Guide individuals or groups Assess potential dangers Create positive customer relations Assemble necessary equipment and supplies Set up and break camp Prepare and/or serve meals Instruct and demonstrate hunting skills and techniques Respect and maintain natural surroundings</p>	<p>Physical ability for most guiding tasks Hunting experience and knowledge is required Knowledge of terrain, environment and local area in which the guide is to travel Ability to get along and work well with others Excellent communication and instruction skills are required Organisational and leadership skills Equipment maintenance and repair skills Outdoor cooking skills Knowledge of relevant laws, safety and emergency procedures Secondary school diploma is usually preferred Standard first aid and CPR</p>	<p>Supervisor Manager Owner/Operator of small business</p>



www.enjoy-language.se

TOURISM PROFESSION CARDS

Kitchen Helper

Job description	Responsibilities	Skills and abilities	Future career path
<p>A kitchen helper cleans and sanitises kitchen equipment, assists in basic food preparation, and with receiving and storing products in kitchens, restaurants, clubs, fast food outlets and catering companies. They have knowledge of general kitchen operations and of general food storage guidelines. This position gives kitchen helpers the opportunity to learn about kitchen and restaurant operations and the opportunity to work with and learn from chefs.</p>	<p>Assist in basic food preparation Clean kitchen equipment Load and unload dishwasher Scrub pots and pans Clean food preparation and storage areas Receive and store goods</p>	<p>Good health condition Ability to lift and carry heavy items properly Demonstrated interest in food preparation and kitchen operations Time management skills Basic food preparation skills Basic cleaning and maintenance skills Knowledge of the products, cooking, sector and industry in general. Secondary school diploma is preferred Courses in first aid, Foodsafe and handling of workplace hazardous materials are asset</p>	<p>Line Cook Apprentice Kitchen Manager Sous Chef Chef Executive Chef Food and Beverage Manager</p>



www.enjoy-language.se

TOURISM PROFESSIONS CARDS 22

TOURISM PROFESSION CARDS

Lift Mechanic

Job description	Responsibilities	Skills and abilities	Future career path
<p>The position of lift mechanic is a full-time, year round, job with a significant amount of responsibility attached. Lift mechanics install, maintain, repair and troubleshoot lift equipment as well as assist lift operations with the start up and shut down of the lifts daily. They also read diagrams and manufacturers' manuals, fit bearings, rebuild sheave trains, service grips and perform other mechanical procedures requiring specialised training. They work at great heights, in all weather conditions, at any time of the day or night.</p>	<p>To perform all duties assigned by Lift Maintenance Manager and Lead hand</p> <p>Ensure all lifts are maintained to CSA Z-98 code and manufacturer's recommendations</p> <p>Assist in emergency situations</p> <p>Report and rectify any unsafe situations</p> <p>Keep a clean, organised and safe work environment</p> <p>Use courtesy and respect when dealing with management, staff, co-workers, and guests at all times</p>	<p>Millwright or apprentice with ski industry experience</p> <p>Good communications skills, self-motivated, mature, dependable, timely and able to work well with others</p> <p>Willing and able to work in all weather conditions</p> <p>Ability to work at excessive heights</p> <p>Valid Class 5 Driver's License</p> <p>Ability to operate snowmobiles, ATVs and 4x4 trucks in a safe and responsible manner</p> <p>Operators certificates for associated industrial equipment an asset</p> <p>Good working knowledge of current WCB regulations</p> <p>Required tools</p>	<p>Lift Mechanic Lead hand</p> <p>Lift Mechanic Supervisor</p> <p>Mountain Maintenance Manager</p> <p>Director of Operations</p> <p>General Manager</p>



www.enjoy-language.se

TOURISM PROFESSION CARDS

Lift Operator

Job description	Responsibilities	Skills and abilities	Future career path
<p>Lift operators are responsible for the safe and efficient operation of mountain chair lifts, and the customers that use them. They spend their days helping customers, of all skill levels, load and unload from lifts, in all kinds of weather. As a result, enjoyment of the outdoors is a must! The job of a lift operator is critical to the success of any ski operation because much of the customer's time is spent with them.</p>	<p>Provide excellent customer service and create positive memories for the guests</p> <p>Operate the assigned lift safely and efficiently</p> <p>Provide physical assistance to guests as required</p> <p>Maintain all operational aspects of the assigned lift – ramps, mazes and signs</p>	<p>Possess excellent employee and public relation skills and enjoy working with the public</p> <p>Mature, energetic, dependable and self-motivated</p> <p>Able to reason and react with quick, thoughtful judgment, while remaining calm under pressure</p> <p>Capable of performing physical/manual duties</p> <p>Enjoy working outdoors in all kinds of weather</p>	<p>Chair boss</p> <p>Lifts lead hand</p> <p>Lifts Supervisor</p> <p>Groomer, Lift Mechanic</p> <p>Operations Manager</p>



www.enjoy-language.se

TOURISM PROFESSIONS CARDS 23

TOURISM PROFESSION CARDS

Line Cook

Job description	Responsibilities	Skills and abilities	Future career path
<p>The Line Cook is responsible for the preparation of high-quality food in a timely, efficient, sanitary and consistent manner. They work in a fast-paced, high-pressure work environment, while maintaining the organisational ability to identify and act on job duties quickly and effectively. They also work as a team member in a dynamic workplace, follow all safety procedures, and have a high threshold for heat in a kitchen environment.</p>	<p>Daily preparation of food items in the pantry, fry and/or stations or other areas of the kitchen Prepare all food items as directed in a sanitary and timely manner Follow recipes, portion controls, and presentation specifications as set by the restaurant Restock all items as needed throughout shift Use and maintain all equipment in station Assist with the cleaning, sanitation, and organisation of kitchen, walk-in coolers, and all storage areas Prepare dishes for customers with food allergies or intolerances</p>	<p>High school diploma Professional diploma Minimum 1 year of cooking experience required Demonstrated knowledge of food and catering trends, quality, production, sanitation, food cost controls, and presentation required Knowledge of methods and procedures for serving food, principles of sanitation Ability to lift up to 50lb Effective communication skills Highly flexible, with solid interpersonal skills that allow one to work effectively in a diverse working</p>	<p>Sous Chef Head Chef Kitchen Manager</p>



www.enjoy-language.se

TOURISM PROFESSION CARDS

Motor Coach Driver

Job description	Responsibilities	Skills and abilities	Future career path
<p>A motor coach driver operates sightseeing or tour buses, and transports passengers locally or over long distances. They have excellent driving records and are able to transport customers safely. They provide for the needs of passengers and offer information about the locale. They are employed by motor coach touring companies or work directly for resorts or hotels.</p>	<p>Make routine checks of coach greet customers Confirm destination and take tickets Assist passengers on and off coach Drive passengers/goods to requested destination Practice defensive driving Provide tour commentary Provide information on locale, attractions, fares, etc. Record transactions and trip log</p>	<p>A valid operator's license is required Four to five years of driving experience Good health and physical fitness Tourism or customer service experience Excellent communication skills Organisational and record-keeping skills are good to have Knowledge of destinations, routes, legislation and regulations an asset Second language is an asset Secondary school diploma is preferred</p>	<p>Tour Director Manager Owner/Operator</p>



www.enjoy-language.se

TOURISM PROFESSIONS CARDS 24

TOURISM PROFESSION CARDS

Museum Curator

Job description	Responsibilities	Skills and abilities	Future career path
Curators are specialists in a particular academic discipline relevant to a historic site/museum/gallery's collection. Museum Curators research and recommend acquisition of artifacts and are responsible for the care of objects, materials and specimens. They have highly specialised skills and knowledge in their areas of study.	<ul style="list-style-type: none"> Interpret materials or artifacts for the public and/or for other museum staff Recommend acquisitions, loans or sales research Authenticate history of artifacts Coordinate the storage of collections Determine proper conversation methods Set up displays and exhibitions Supervise assistants 	<ul style="list-style-type: none"> Advanced university degree with a concentration in a discipline related to a relevant area of the museum's collections is required Excellent communication skills are required Previous experience in a museum, gallery or related educational or research organisation is generally required Excellent research and writing skills Specialised knowledge in the area relevant to museum collections Excellent interpretation skills Working knowledge of the ethics of collecting Knowledge of customs regulations is an asset 	<ul style="list-style-type: none"> General Manager Owner/Operator



www.enjoy-language.se

TOURISM PROFESSION CARDS

Nightclub Manager

Job description	Responsibilities	Skills and abilities	Future career path
Nightclub Managers direct, plan and control all aspects of a nightclub in hotels, resorts and private clubs.	<ul style="list-style-type: none"> Ensure the effective and compliant operations of the nightclub; such as following legislation and safety codes Ensure the financial integrity of the operation; such as maintaining and monitoring cash flow, handling bank deposits and overseeing accounting procedures Assist in promotion and sales Maintain records Conduct regular inspections of operation Resolve customer complaints Manage human resources, such as recruitment, training and scheduling staff 	<ul style="list-style-type: none"> A diploma or degree in hospitality or food and beverage management is generally required Courses in business, management, marketing, accounting, alcohol service, safe food handling, first aid or service training are assets Proven supervisory or management experience is required Food and beverage experience is required Good customer service skills Good communication skills Financial planning and budgeting experience is an asset Time management skills are an asset 	<ul style="list-style-type: none"> Beverage Services Manager Food and Beverage Director General Manager Owner/Operator



www.enjoy-language.se

TOURISM PROFESSIONS CARDS 25

TOURISM PROFESSION CARDS

Outdoor Adventure Guide

Job description	Responsibilities	Skills and abilities	Future career path
<p>Outdoor adventure guides organise and conduct expeditions for sports enthusiasts, adventurers, tourists or resort guests. They work for adventure tourism companies, resorts, parks, lodges or campgrounds, or they operate their own small businesses. They might take clients white water rafting, fishing, hunting, or mountain climbing, depending on the season and on their skills. Often the work is seasonal, and, depending on the type of guiding, the hours can be irregular.</p>	<p>Guide individuals or groups Create positive customer relations Assemble necessary equipment and supplies Set up and break camp Prepare and/or serve meals Instruct and demonstrate related skills and techniques Respect and maintain natural resources</p>	<p>A secondary school diploma Ability to deal with physical demands of the position Standard first aid and CPR are generally required Additional health and safety training is an asset Previous experience in the relevant sport or activity is required Ability to work in teams Excellent communication and instructional skills Good organisational and leadership skills Working knowledge of terrain, environment and local area Working knowledge of relevant legislation Mountain guides must be accredited</p>	<p>Supervisor Manager Owner/Operator of a small business</p>



www.enjoy-language.se

TOURISM PROFESSION CARDS

Parking Lot Attendant – Ski Resort

Job description	Responsibilities	Skills and abilities	Future career path
<p>As part of the guest services department the Parking Lot attendant provides guest with parking directions and information about the resort and with any other services they require. Work can be very fast-paced, especially during the high season, and Parking Lot attendants are often the eyes and ears of the resort, as they are constantly moving around it, and often notice issues that need attending to. Responsibilities:</p>	<p>Ensure the parking spaces are sufficient for each individual vehicle Ensure the parking lots are filled to maximum capacity Allot parking spaces with preference to size of vehicles Ensure you are clearly identifiable to visitors/guests Set up safety cones Provide guests with verbal information about the resort facilities, services and attractions Keep supervisor up-to-date with parking lot capacity Ensure the parking lots are kept clean and tidy Record and resolve all Customer complaints and comments</p>	<p>Professional attitude Ability to work as a member of a team Good communication skills Customer service skills Enjoy working with people Additional languages an asset</p>	<p>Parking Supervisor Parking Manager</p>



www.enjoy-language.se

TOURISM PROFESSIONS CARDS 26

TOURISM PROFESSION CARDS

Patroller

Job description	Responsibilities	Skills and abilities	Future career path
Being a patroller on a mountain requires a wide variety of skills and abilities. Job responsibilities vary from administering first aid and avalanche control to signing the mountain and marking hazards and monitoring skiers and boarders to ensure safe conduct on the hill. These crews are committed mountain people who love to work in a variety of conditions.	<p>First aid for guests and staff</p> <p>Risk management, hazard prevention and marking</p> <p>Lift evacuation</p> <p>Assist in avalanche control</p> <p>Assist in search and rescue</p> <p>Snowmobile operation and safety</p> <p>Weather observation and reporting</p> <p>Mountain dispatch</p> <p>Public relations</p>	<p>Occupational First Aid level III</p> <p>Strong alpine skier/boarder in all snow terrain and conditions</p> <p>Proficient in operation of snowmobiles</p> <p>Strong toboggan handling and teaching skills</p> <p>High level of fitness and able to work in all weather conditions</p> <p>Self motivated with strong interpersonal skills</p> <p>Previous ski hill experience an asset</p>	<p>Level 2 Patroller</p> <p>Level 3 Patroller</p> <p>Patrol Supervisor</p> <p>Operations manager</p>



www.enjoy-language.se

TOURISM PROFESSION CARDS

Ski/Snowboard Instructor

Job description	Responsibilities	Skills and abilities	Future career path
Ski and Snowboard Instructors have the enviable job of spending their days on the slopes. These patient individuals teach everyone from wee tots to active seniors how to improve their skiing and snowboarding skills. They are also ambassadors on the mountain to ensure guests have a successful day and will return. The work is dependant on customer demand, so ski breaks are common within the work day.	<p>Teaching duties relative to certification and experience with adults and or children in both groups and private lessons</p> <p>Participation in training clinics</p> <p>Be familiar with lessons and pricing to continue to promote skill development</p> <p>Actively assist guests to remain in the sport</p>	<p>Professional ski and snowboard instructor qualifications</p> <p>Outstanding verbal and written skills</p> <p>Polished interpersonal and motivational skills</p> <p>Highly organised</p> <p>Team player</p> <p>Second language a definite asset</p>	<p>Level II instructor</p> <p>Level III instructor</p> <p>Level IV instructor</p> <p>Snow School Lead hand</p> <p>Snow School Supervisor</p> <p>Snow School Director</p> <p>Resort Operations Manager</p> <p>Director of resort operations</p> <p>General Manager</p>



www.enjoy-language.se

TOURISM PROFESSIONS CARDS 27

TOURISM PROFESSION CARDS

Small Business Owner/Operator

Job description	Responsibilities	Skills and abilities	Future career path
<p>Tourism Small Business Owner/Operators are accountable for planning, decision-making and management of all aspects of the tourism business. An Owner/Operator must continuously review and update business plans, check budget figures, monitor accounting and cash control procedures and ensure the overall operation of the establishment is in line with predictions.</p> <p>Responsibilities:</p>	<p>Meet and exceed guests' expectations</p> <p>Offer tourism information and promote local area</p> <p>Use business management skills</p> <p>Use sales and marketing skills</p> <p>Complete financial management tasks</p> <p>Use administrative skills</p> <p>Respond to enquiries and solve problems</p> <p>Maintain facility, equipment and supplies</p>	<p>A secondary school diploma</p> <p>A college diploma or degree in business, tourism, marketing or management</p> <p>Training in both first aid and small business management</p> <p>Previous experience in tourism is required</p> <p>Excellent organisational and administrative skills</p> <p>Sales and marketing skills are an asset</p> <p>Customer service skills</p> <p>Accounting and cash control skills</p> <p>Leadership skills</p> <p>Human resource management skills</p>	<p>Expand business</p> <p>Purchase larger operation</p> <p>Bed and Breakfast Owner/Operator</p> <p>Campground Operator</p> <p>Manager/Executive in other tourism businesses</p>



www.enjoy-language.se

TOURISM PROFESSION CARDS

Snow Maker

Job description	Responsibilities	Skills and abilities	Future career path
<p>This job involves working as part of a team to open and maintain skiing terrain with the best possible snow that can be created.</p>	<p>Produce quality snow through the use of both air/water and fan equipment</p> <p>Work up to 12 hour shifts between 12:00 am until 12:00 noon, typically in alternating 3 or 4 day periods (weather permitting)</p> <p>Perform all tasks safely as per Industrial Health and Safety Regulations</p> <p>Work closely with, and assist other departments</p> <p>Operate various electrical and pressurised air and water equipment</p> <p>Operate various types of motorized equipment on and off the mountain</p> <p>Abide by all mountain rules and regulations at all times on or off the job</p>	<p>Good teamwork skills</p> <p>Physically able to perform manual tasks</p> <p>Capable of working outdoors in all weather conditions</p> <p>Ability to think and work independently</p> <p>Ability to ski or snowboard at a minimum intermediate level</p> <p>Good mechanical aptitude, preferably demonstrated in previous experience</p> <p>Valid BC driver's license and satisfactory driver's abstract</p> <p>Snowmaking experience is an asset</p> <p>Skidoo and/or snowcat experience is an asset</p> <p>Knowledge of mountain terrain and operations is an asset</p>	<p>Mountain operations or maintenance management</p>



www.enjoy-language.se

TOURISM PROFESSIONS CARDS 28

TOURISM PROFESSION CARDS

Sous-chef

Job description	Responsibilities	Skills and abilities	Future career path
<p>Sous-chefs plan and direct food preparation and cooking activities. Sous-chefs prepare and cook meals and specialty foods. They are employed in restaurants and hotels and similar establishments on cruise ships. Sous-chefs are often considered an entry level management position. The position of sous-chef generally demands 25% of their time in the office and 75% of their time in the kitchen.</p>	<p>Supervise activities of all kitchen staff, including chefs and specialty chefs Staff scheduling Performance management of staff including discipline Involvement in menu and product research and development Ensures appropriate health and safety standards, FOODSAFE practices Monitors apprenticeship development May have involvement in formulation of job descriptions Equipment performance monitoring, may demonstrate use of new equipment Inventory management</p>	<p>A secondary school diploma is usually required Related post secondary education is usually preferred A few to several years of previous experience in commercial food preparation is required Proficient with labour law Proficient with health and safety rules and regulations Ability to coach and mentor other staff Excellent communication skills Ability to deal with high pressure environments Good decision making skills</p>	<p>Executive Sous-Chef Executive Chef Owner of Restaurant</p>



www.enjoy-language.se

TOURISM PROFESSION CARDS

Special Events Coordinator

Job description	Responsibilities	Skills and abilities	Future career path
<p>Special Events Coordinators assist in the preparation, implementation, execution and evaluation of special events. They help with human resource coordination by recruiting, training and motivating staff and volunteers. It is a job that requires creativity and the use of many talents. Event Coordinator positions may be short-term contracts, and many Event Coordinators move from contract to contract, event to event.</p>	<p>Administer financial controls and procedures Implement event plan, including programme, site development, equipment, staging, seating and parking Coordinate office administration Fulfill marketing plan, including advertising, trade shows, contests and volunteer/sponsor appreciation programmes Recruit, train, supervise and evaluate staff and volunteers Prepare/deliver written and verbal communications</p>	<p>A diploma or degree in communications, marketing, business administration or tourism management is usually required Strong written and verbal communication skills Ability to be an effective team member Excellent organisational skills Excellent project management skills Public relations and HR skills Marketing skills are an asset Ability to motivate others Negotiation skills are an asset</p>	<p>Convention/ Meeting Planner Special Events Manager Owner/Operator</p>



www.enjoy-language.se

TOURISM PROFESSIONS CARDS 29

TOURISM PROFESSION CARDS

Taxi Driver and Limousine Driver

Job description	Responsibilities	Skills and abilities	Future career path
<p>A taxi driver and limousine driver drives automobiles and limousines to transport passengers. They are employed by taxi driver companies or work as independent drivers. They have extensive and detailed knowledge of the area in which they drive. They must have and maintain an excellent driving record and are able to transport customers safely from point A to point B via the most direct and/or practical route possible.</p>	<p>Greet customers Assist passengers as they enter and exit vehicle Stow luggage and other goods Drive passengers and/or goods to requested destination Practice defensive driving Provide information on locale, attractions, fares, etc. Handle customer complaints or difficult passengers Process payment and record transactions Communicate with dispatcher</p>	<p>Professional appearance and attitude Valid driver's licence (Class G/4) and a good driving record is required Good judgment and problem-solving skills Good communication skills Customer service skills Experience in cash handling Time management skills Second language is an asset</p>	<p>Chauffeur Dispatcher Manager of Operations Owner/Operator</p>



www.enjoy-language.se

TOURISM PROFESSION CARDS

Ticket Office Supervisor

Job description	Responsibilities	Skills and abilities	Future career path
<p>The ticket office supervisor needs to be a versatile individual, as they are responsible for the accuracy of ticket sales from programming to selling, cash control as well as taking exceptional care of guests purchasing tickets. Key to this position is making sure staff are well trained and able to inform each guest of their best ticketing option.</p>	<p>Knowledgeable of all ticketing options Hire, train and supervise ticket selling staff Provide front line support and on going training to frontline ticket selling staff Accountable for the accurate and timely submission of cashouts Responsible for all cash and cash equivalents in ticketing area Schedule staff, matching predetermined budget while keeping in mind weather and visitor patterns Assist in area budgeting</p>	<p>Previous ticket selling experience preferred Previous mountain experience preferred Cash handling experience a must Excellent interpersonal and communication skills Team player Strong organisational skills Customer service orientated Very comfortable with all aspects of computer systems</p>	<p>Cash room supervisor Season pass coordinator Guest services positions, including management</p>



www.enjoy-language.se

TOURISM PROFESSIONS CARDS 30

TOURISM PROFESSION CARDS

Tour Operator

Job description	Responsibilities	Skills and abilities	Future career path
<p>Tour Operators are involved in planning, development, promotion, administration and implementation of tourism products. They oversee all the day-to-day tasks and also supervise, motivate and train staff. They are employed by tour or transportation companies, resorts or attractions. They may travel to proposed tour sites, check them out and experience the services first hand before assessing their tourism potential.</p>	<p>Use operations management skills Use sales and marketing skills Manage human resources Develop products Use financial management skills</p>	<p>A secondary school diploma is required A university degree or college diploma in tourism or history is an asset Previous management and tourism experience is an asset Human resource management skills Leadership skills Team-building skills Financial management skills are required Good communication and customer service skills Knowledge of relevant destinations, attractions and travel are important Research skills are an asset Knowledge of a second language is an asset</p>	<p>Senior Manager General Manager Owner/Operator of tour operation</p>



www.enjoy-language.se

TOURISM PROFESSION CARDS

Tourism Researcher

Job description	Responsibilities	Skills and abilities	Future career path
<p>Tourism Researchers provide market research, analysis, planning and marketing strategies/services for tourism-related businesses. They collect, analyse and report findings back to clients and may need to conduct comparative research studies and/or develop social economic profiles. Researchers are employed by governments, by private consulting/research firms or by professional associations.</p>	<p>Provide research, analysis and planning services Identify and recommend marketing opportunities Prepare marketing and development strategies Respond to enquiries regarding reports Design, develop and implement projects, events, campaigns, etc.</p>	<p>A bachelor degree in economics, commerce, business or public administration is required Previous experience in market research or marketing Strong verbal and written communication skills Excellent research skills Analytical skills Planning skills Knowledge of basic computer applications</p>	<p>Manager Executive or Owner/Operator in private industry Researcher in government agency</p>



www.enjoy-language.se

TOURISM PROFESSIONS CARDS 31

TOURISM PROFESSION CARDS

Tourism/Visitor Information Counsellor

Job description	Responsibilities	Skills and abilities	Future career path
<p>Tourism/Visitor Information Counsellors are an important link between the visitor and the service providers. They work at visitor information centres, government offices or at association offices, and provide answers to questions about the area, history, attractions and weather. Much of their time is spent talking to guests.</p>	<p>Answer questions and provide information specific to region or site Distribute promotional materials Promote tourism products Encourage new and return visits Gather information and develop new resources Perform administrative tasks May also stock and sell merchandise and handle cash transactions</p>	<p>Completion of secondary school is required A college diploma or vocational training in tourism is preferred Excellent communication skills are required Good customer service skills Knowledge of attractions, events and the local area is also required Research skills are an asset Previous experience in sales and cash handling is an asset Inventory and administrative skills Time management skills are an asset Knowledge of a second language is an asset</p>	<p>Tourism/Visitor Information Centre Supervisor Regional General Manager</p>



www.enjoy-language.se

TOURISM PROFESSION CARDS

Trade Show Guide

Job description	Responsibilities	Skills and abilities	Future career path
<p>A trade show guide serves as a host to individuals or groups at trade shows, exhibitions and conferences. They may describe points of interest and supply information, or escort a party through a show or centre. The position offers an excellent opportunity to network and learn about trade shows and the sector in general, as well as about what the event is promoting.</p>	<p>Meet and greet visitors Respond to questions or concerns Hand out trade show maps and guides Guide visitors to display, or offer directions Fill out any required tracking data, statistics, etc.</p>	<p>An interest in the subject area of the event Good communication skills Physical ability to stand and/or walk Professional attitude and appearance Willingness to work with people Customer service skills Presentation experience Knowledge of trade show products and industry Second language is an asset Secondary school diploma is preferred Knowledge of the Local Tour Guide National Occupational Standards may be an asset</p>	<p>Supervisor of Trade Show Guides Meeting Planner</p>



www.enjoy-language.se

TOURISM PROFESSIONS CARDS 32

TOURISM PROFESSION CARDS

Trade Show Registration Clerk

Job description	Responsibilities	Skills and abilities	Future career path
<p>A trade show registration clerk looks after all aspects of registering delegates to a meeting, conference or event. Much is done prior to the event, such as researching the list of potential clients, preparing the registration package materials and then sending them out. When forms are returned, the information is collated, and an attendee list is prepared. During the event, a registration clerk keeps track of the number of attendees, and may help or oversee the work of the trade show guides.</p>	<p>Prepare and send mailings to members and others Set up registration area and system for tracking pre-registered delegates Greet/register delegates Provide information, give directions and answer enquiries Record and report attendance figures</p>	<p>Good communication and organisational skills Cash handling experience Meeting and convention experience Registration experience Customer service experience Time management skills an asset Secondary school diploma is preferred Knowledge of the Entry Level Skills National Occupational Standards is an asset</p>	<p>Registration Supervisor Registration Manager</p>



www.enjoy-language.se

TOURISM PROFESSION CARDS

Travel Agency Manager

Job description	Responsibilities	Skills and abilities	Future career path
<p>A travel agency manager plans, organises, directs and controls the operations of travel-related organisations. They also co-ordinate and direct the activities of staff, overseeing not only the day-to-day tasks, but the hiring, training and evaluating of staff members as well. Agency managers may also research new products and destinations, often by traveling to them and experiencing first hand the services available.</p>	<p>Use operations management skills, such as establishing work plans and objectives Use financial management skills, such as overseeing budget Manage human resources, such as hiring and training staff Use sales and marketing skills, such as determining potential markets Co-ordinate merchandising functions through retail buyers Research new products</p>	<p>Strong written and verbal communication skills Proven sales and marketing abilities Organisational and planning skills HR and financial management skills Marketing, research and selling skills Travel and/or management experience Strong leadership and team-building skills Time and risk management skills an asset Second language an asset Several years of related retail sales experience Diploma or degree in tourism, business or management may be necessary</p>	<p>Tour Operator General Manager Regional Manager Agency Owner/Operator</p>



www.enjoy-language.se

TOURISM PROFESSIONS CARDS 33

TOURISM PROFESSION CARDS

Travel Counsellor

Job description	Responsibilities	Skills and abilities	Future career path
<p>A travel counsellor advises clients on travel options and tour packages, makes bookings and reservations, prepares tickets and receives payment. They are enthusiastic about travel, and have good research and organisational skills. In addition to salaries, travel counselors also may be offered commissions and travel benefits. They are employed in retail travel agencies, wholesale tour companies and in corporate offices that have enough business travel to warrant their own booking divisions.</p>	<p>Provide travel information and itineraries to clients Counsel clients on terms and conditions of travel, e.g. cancellation policies Sell tickets/tours and make reservations Process payments and keep accounts Promote destinations, tour packages and other services Provide travel tips on currency, language, safety, health, etc. May also sell special event tickets or travel insurance</p>	<p>Strong written and verbal communication skills Customer service and interpersonal skills Aptitude for selling Ability to work under pressure Sales and marketing experience Computer experience Monetary transaction skills Proven research, organisational and time management skills Travel experience an asset Second language an asset Secondary school diploma is required Related college diploma is usually requested</p>	<p>Senior Travel Counsellors Travel Agency Manager Agency Owner/Operator</p>



www.enjoy-language.se

TOURISM PROFESSION CARDS

Travel Trade Sales Manager

Job description	Responsibilities	Skills and abilities	Future career path
<p>A manager of travel trade sales is responsible for promoting a destination to travel agencies and tour companies. Government agencies, private consulting and research firms and professional associations all employ these managers. They may travel frequently, exploring new destinations and discovering travel attractions.</p>	<p>Use administrative skills Use sales and marketing skills Use financial management skills Attend travel shows Organise familiarisation tours</p>	<p>Knowledge of destination travel products, Experience in government, business, tourism or travel trade Experience in marketing or business development Research, analytical planning and sales skills Management or supervisory experience Strong verbal and written communications skills Proven financial management skills Development and management of campaigns An extended network of contacts University degree or college diploma in tourism, business, marketing</p>	<p>Executive Owner/Operator</p>



www.enjoy-language.se

TOURISM PROFESSIONS CARDS 34

TOURISM PROFESSION CARDS

Travel Writer/Photographer

Job description	Responsibilities	Skills and abilities	Future career path
<p>A travel writer and photographer is a specialist who often travels to far-away destinations to develop stories and photos for tourism-related journalism. They may be employed by newspapers, magazines, trade publications, the government or as freelance writers and photographers.</p>	<p>Research subject travel to and explore destinations Conduct interviews Deliver work, often by electronic means Write and edit articles prior to editorial review (writer only) Take photographs, identify/gain consent of subject (photographer only) Develop and enhance photographs (photographer only)</p>	<p>Creative ability Good communication skills Technical skills such as computer literacy and ability to use electronic mail (writer only) Experience in research, interviewing and writing travel stories is desired (writer only) Technical skills such as ability to use cameras and related equipment (photographer only) Photography experience (photographer only) Diploma or degree in Journalism (writer only) Diploma or degree in Visual Arts or Photography (photographer only)</p>	<p>Publisher Assistant Editor or Editor (writer only) Communications Director (writer only) Assistant Art Director or Art Director (photographer only)</p>



www.enjoy-language.se

TOURISM PROFESSION CARDS

Visitor Information Centre Supervisor

Job description	Responsibilities	Skills and abilities	Future career path
<p>Tourism Visitor Information Centre (VIC) Supervisors oversee the day-to-day operation of a tourism/visitor information centre, assisting visitors by providing information, as well as supervising staff and carrying out administrative functions. They often perform the same tasks as a Tourism/Visitor Information Counsellor, but must divide their time between those duties and the supervisory duties of planning, operations management and staff supervision.</p>	<p>Manage human resources, such as scheduling staff and conducting training Oversee information services Resolve problems and respond to feedback Perform administrative tasks Gather information and develop new resources Use business management skills</p>	<p>Post secondary training, such as a college diploma or degree in tourism or business, is usually required Previous experience in supervisory or customer service role is required Extensive knowledge of local attractions, events and tourism services is required Excellent communication skills Administrative skills Time management skills</p>	<p>Information Centre Manager Regional General Manager</p>



www.enjoy-language.se

TOURISM PROFESSIONS CARDS 35

TOURISM PROFESSION CARDS

Warehouse Worker - Retail Distribution Centre - Ski Resort

Job description	Responsibilities	Skills and abilities	Future career path
<p>This position is responsible for the receiving, transferring and tracking of all retail/rental products in a ski resort's retail distribution centre. It requires dealing with products and accompanying paperwork with a meticulous attention to detail and procedure.</p>	<p>Operate Apropos back office inventory control system</p> <p>Follow receiving procedures completely and accurately</p> <p>Delivering and logging of all products to and from stores and suppliers</p> <p>Moving and storing of products in their assigned storage locations</p> <p>Setting up and changing over of stores</p> <p>Taking part in warehouse cleanliness, organisation, and recycling</p> <p>Taking an active role in small inventory counts</p> <p>Fill in stock orders for store orders with 100% accuracy</p> <p>Keep records in neat and legible manner</p>	<p>High attention to detail</p> <p>Highly motivated, able to work well with little or no supervision</p> <p>A strong team player</p> <p>Strong communication skills and high level of professionalism</p> <p>Strong organisational skills</p> <p>Strong willingness to learn and take initiative</p> <p>Must perform tasks on schedule and be accountable for deadlines; remain focused on task</p> <p>Must be capable of regularly lifting 30 lbs on a daily basis</p> <p>Retail operations experience an asset</p>	<p>Retail management</p> <p>Inventory or accounting</p>



www.enjoy-language.se

TOURISM PROFESSION CARDS

Wine Server

Job description	Responsibilities	Skills and abilities	Future career path
<p>Wine Servers recommend and serve wine to guests. They work in hotels, private clubs, dining rooms and on cruise ships. Wine Servers have extensive knowledge of wine, which allows them to match appropriate wines to customers' tastes. The position of Wine Server may be combined with the role of Maitre D' or Food and Beverage Supervisor, depending on the establishment. Wine Servers usually receive gratuities and may also receive meals or discounts on meals when at work.</p>	<p>Provide excellent customer service</p> <p>Provide information on wine characteristics, wine production and types of wine</p> <p>Evaluate and sell wine using accepted techniques and guidelines</p> <p>Prepare and serve wine using wine service techniques</p> <p>Order and maintain wine inventory</p> <p>Practice responsible alcohol service</p>	<p>A secondary school diploma</p> <p>Courses in bartending, responsible alcohol service, wines, first aid and service excellence are recommended</p> <p>Good communication and customer service skills</p> <p>Professional appearance and attitude</p> <p>Extensive knowledge of wines and wine production methods is required</p> <p>They must also be of legal drinking age</p> <p>Inventory management skills are an asset</p> <p>Knowledge of relevant laws and regulations are an asset</p>	<p>Food and Beverage Service Supervisor</p> <p>Beverage Services Manager</p> <p>Assistant Manager</p> <p>Manager</p> <p>Owner/Operator</p>



www.enjoy-language.se

TOURISM PICTURE CARDS 1



ENJOY LANGUAGE

TOURISM PICTURE FLASHCARDS

www.enjoy-language.se

A project financed under the Life Long Learning Programme
(LLP-Ldv/TOI/SE/11/1383 - 2011-1-SE1-LEO05-08376)

TOURISM PICTURE CARDS



www.enjoy-language.se

TOURISM PICTURE CARDS



www.enjoy-language.se

TOURISM PICTURE CARDS



www.enjoy-language.se

TOURISM PICTURE CARDS



www.enjoy-language.se

TOURISM PICTURE CARDS



www.enjoy-language.se

TOURISM PICTURE CARDS

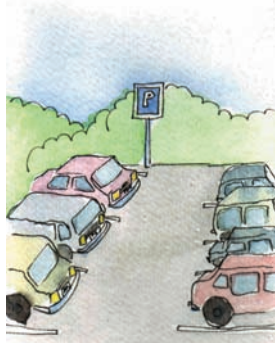

www.enjoy-language.se

TOURISM PICTURE CARDS



www.enjoy-language.se

TOURISM PICTURE CARDS 2

TOURISM PICTURE CARDS



www.enjoy-language.se

TOURISM PICTURE CARDS



www.enjoy-language.se

TOURISM PICTURE CARDS



www.enjoy-language.se

TOURISM PICTURE CARDS



www.enjoy-language.se

TOURISM PICTURE CARDS



www.enjoy-language.se

TOURISM PICTURE CARDS



www.enjoy-language.se

TOURISM PICTURE CARDS



www.enjoy-language.se

TOURISM PICTURE CARDS

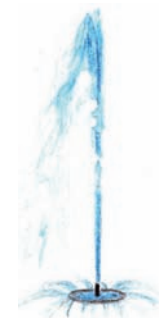

www.enjoy-language.se

TOURISM PICTURE CARDS 3

TOURISM PICTURE CARDS



www.enjoy-language.se

TOURISM PICTURE CARDS



www.enjoy-language.se

TOURISM PICTURE CARDS



www.enjoy-language.se

TOURISM PICTURE CARDS

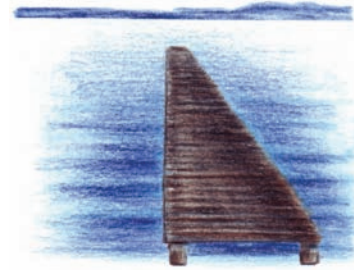

www.enjoy-language.se

TOURISM PICTURE CARDS

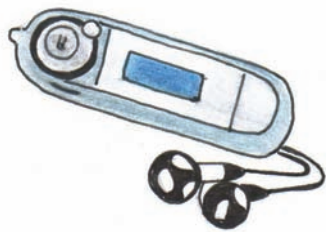

www.enjoy-language.se

TOURISM PICTURE CARDS



www.enjoy-language.se

TOURISM PICTURE CARDS

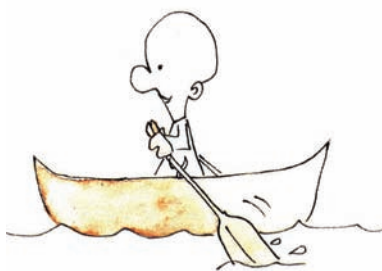

www.enjoy-language.se

TOURISM PICTURE CARDS

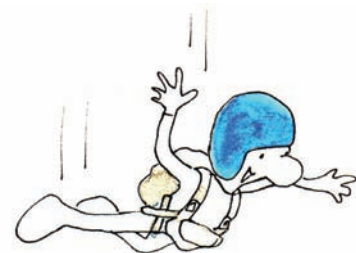

www.enjoy-language.se

TOURISM PICTURE CARDS 4

TOURISM PICTURE CARDS

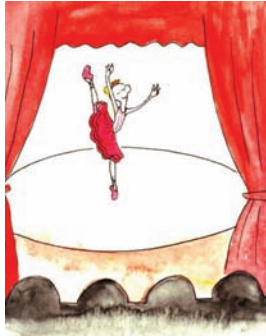

www.enjoy-language.se

TOURISM PICTURE CARDS



www.enjoy-language.se

TOURISM PICTURE CARDS



www.enjoy-language.se

TOURISM PICTURE CARDS



www.enjoy-language.se

TOURISM PICTURE CARDS



www.enjoy-language.se

TOURISM PICTURE CARDS

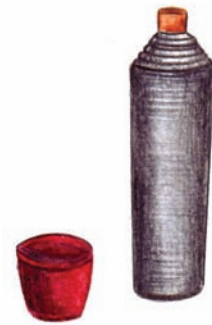

www.enjoy-language.se

TOURISM PICTURE CARDS



www.enjoy-language.se

TOURISM PICTURE CARDS



www.enjoy-language.se

TOURISM PICTURE CARDS 5

TOURISM PICTURE CARDS



www.enjoy-language.se

TOURISM PICTURE CARDS



www.enjoy-language.se

TOURISM PICTURE CARDS

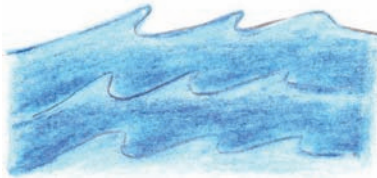

www.enjoy-language.se

TOURISM PICTURE CARDS



www.enjoy-language.se

TOURISM PICTURE CARDS



www.enjoy-language.se

TOURISM PICTURE CARDS



www.enjoy-language.se

TOURISM PICTURE CARDS



www.enjoy-language.se

TOURISM PICTURE CARDS



www.enjoy-language.se

TOURISM PICTURE CARDS 6

TOURISM PICTURE CARDS



www.enjoy-language.se

TOURISM PICTURE CARDS



www.enjoy-language.se

TOURISM PICTURE CARDS



www.enjoy-language.se

TOURISM PICTURE CARDS



www.enjoy-language.se

TOURISM PICTURE CARDS



www.enjoy-language.se

TOURISM PICTURE CARDS



www.enjoy-language.se

TOURISM PICTURE CARDS



www.enjoy-language.se

TOURISM PICTURE CARDS



www.enjoy-language.se

TOURISM PICTURE CARDS 7

TOURISM PICTURE CARDS

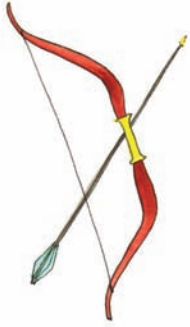

www.enjoy-language.se

TOURISM PICTURE CARDS



www.enjoy-language.se

TOURISM PICTURE CARDS

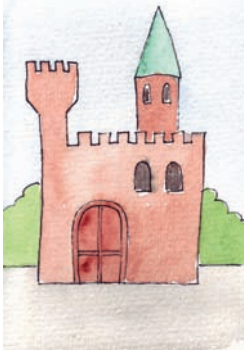

www.enjoy-language.se

TOURISM PICTURE CARDS



www.enjoy-language.se

TOURISM PICTURE CARDS



www.enjoy-language.se

TOURISM PICTURE CARDS



www.enjoy-language.se

TOURISM PICTURE CARDS



www.enjoy-language.se

TOURISM PICTURE CARDS



www.enjoy-language.se

TOURISM PICTURE CARDS 8

TOURISM PICTURE CARDS



www.enjoy-language.se

TOURISM PICTURE CARDS



www.enjoy-language.se

TOURISM PICTURE CARDS



www.enjoy-language.se

TOURISM PICTURE CARDS



www.enjoy-language.se

TOURISM PICTURE CARDS

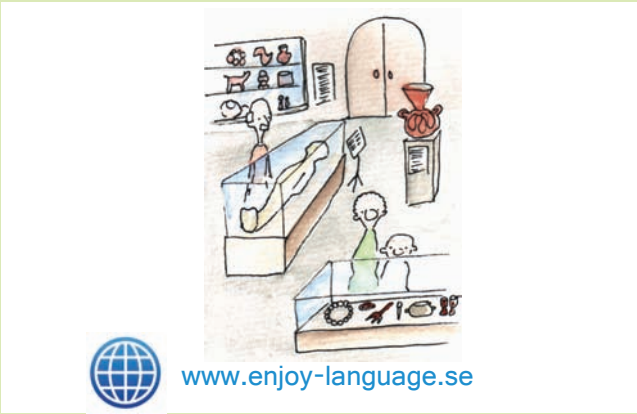

www.enjoy-language.se

TOURISM PICTURE CARDS



www.enjoy-language.se

TOURISM PICTURE CARDS



www.enjoy-language.se

TOURISM PICTURE CARDS



www.enjoy-language.se

TOURISM PICTURE CARDS 9

TOURISM PICTURE CARDS



www.enjoy-language.se

TOURISM PICTURE CARDS



www.enjoy-language.se

TOURISM PICTURE CARDS



www.enjoy-language.se

TOURISM PICTURE CARDS



www.enjoy-language.se

TOURISM PICTURE CARDS



www.enjoy-language.se

TOURISM PICTURE CARDS



www.enjoy-language.se

TOURISM PICTURE CARDS



www.enjoy-language.se

TOURISM PICTURE CARDS



www.enjoy-language.se

TOURISM VOCABULARY CARDS 1



ENJOY LANGUAGE

TOURISM VOCABULARY

www.enjoy-language.se

A project financed under the
Life Long Learning Programme

TOURISM VOCABULARY

amusement



www.enjoy-language.se

TOURISM VOCABULARY

charter



www.enjoy-language.se

TOURISM VOCABULARY

chef



www.enjoy-language.se

TOURISM VOCABULARY

cruise ship



www.enjoy-language.se

TOURISM VOCABULARY

comfortable



www.enjoy-language.se

TOURISM VOCABULARY

entertainment



www.enjoy-language.se

TOURISM VOCABULARY

gastronomy



www.enjoy-language.se

TOURISM VOCABULARY

kid-friendly



www.enjoy-language.se

TOURISM VOCABULARY

leisure park



www.enjoy-language.se

TOURISM VOCABULARY

luxurious



www.enjoy-language.se

TOURISM VOCABULARY

open-air café



www.enjoy-language.se

TOURISM VOCABULARY

partying



www.enjoy-language.se

TOURISM VOCABULARY

playground



www.enjoy-language.se

TOURISM VOCABULARY

recreation



www.enjoy-language.se



TOURISM VOCABULARY CARDS 2

TOURISM VOCABULARY

regatta



www.enjoy-language.se

TOURISM VOCABULARY

relaxation



www.enjoy-language.se

TOURISM VOCABULARY

souvenir



www.enjoy-language.se

TOURISM VOCABULARY

spa



www.enjoy-language.se

TOURISM VOCABULARY

sunscreen



www.enjoy-language.se

TOURISM VOCABULARY

swimming pool



www.enjoy-language.se

TOURISM VOCABULARY

theme park



www.enjoy-language.se

TOURISM VOCABULARY

time off



www.enjoy-language.se

TOURISM VOCABULARY

walk



www.enjoy-language.se

TOURISM VOCABULARY

weekend



www.enjoy-language.se

TOURISM VOCABULARY

volleyball



www.enjoy-language.se

TOURISM VOCABULARY

archaeology



www.enjoy-language.se

TOURISM VOCABULARY

authenticity



www.enjoy-language.se

TOURISM VOCABULARY

charter tour



www.enjoy-language.se

TOURISM VOCABULARY

church



www.enjoy-language.se



TOURISM VOCABULARY CARDS 3

TOURISM VOCABULARY

crafts



www.enjoy-language.se

TOURISM VOCABULARY

custom tour



www.enjoy-language.se

TOURISM VOCABULARY

ethnic fair



www.enjoy-language.se

TOURISM VOCABULARY

ground operator



www.enjoy-language.se

TOURISM VOCABULARY

heritage site



www.enjoy-language.se

TOURISM VOCABULARY

itinerary



www.enjoy-language.se

TOURISM VOCABULARY

knowledge



www.enjoy-language.se

TOURISM VOCABULARY

landmark



www.enjoy-language.se

TOURISM VOCABULARY

lifestyle



www.enjoy-language.se

TOURISM VOCABULARY

restoration



www.enjoy-language.se

TOURISM VOCABULARY

ruins



www.enjoy-language.se

TOURISM VOCABULARY

bakery



www.enjoy-language.se

TOURISM VOCABULARY

bus tour group



www.enjoy-language.se

TOURISM VOCABULARY

eco-friendly



www.enjoy-language.se

TOURISM VOCABULARY

escorted
walking tour



www.enjoy-language.se



TOURISM VOCABULARY CARDS 4

TOURISM VOCABULARY

flea market



www.enjoy-language.se

TOURISM VOCABULARY

food



www.enjoy-language.se

TOURISM VOCABULARY

healthy



www.enjoy-language.se

TOURISM VOCABULARY

map



www.enjoy-language.se

TOURISM VOCABULARY

milking
demonstration



www.enjoy-language.se

TOURISM VOCABULARY

nature
photography



www.enjoy-language.se

TOURISM VOCABULARY

pick-your own
farm



www.enjoy-language.se

TOURISM VOCABULARY

star gazing



www.enjoy-language.se

TOURISM VOCABULARY

trail



www.enjoy-language.se

TOURISM VOCABULARY

wildlife



www.enjoy-language.se

TOURISM VOCABULARY

winery



www.enjoy-language.se

TOURISM VOCABULARY

caving



www.enjoy-language.se

TOURISM VOCABULARY

compass



www.enjoy-language.se

TOURISM VOCABULARY

sky diving



www.enjoy-language.se

TOURISM VOCABULARY

hard adventure



www.enjoy-language.se



TOURISM VOCABULARY CARDS 5

TOURISM VOCABULARY

river kayaking



www.enjoy-language.se

TOURISM VOCABULARY

horseback riding



www.enjoy-language.se

TOURISM VOCABULARY

rock mountain
climbing



www.enjoy-language.se

TOURISM VOCABULARY

off-road cycling
tour



www.enjoy-language.se

TOURISM VOCABULARY

safari



www.enjoy-language.se

TOURISM VOCABULARY

sign



www.enjoy-language.se

TOURISM VOCABULARY

soft adventure



www.enjoy-language.se

TOURISM VOCABULARY

survival &
wilderness training



www.enjoy-language.se

TOURISM VOCABULARY

wildlife trip



www.enjoy-language.se

TOURISM VOCABULARY

risk



www.enjoy-language.se

TOURISM VOCABULARY

travel



www.enjoy-language.se

TOURISM VOCABULARY

worry



www.enjoy-language.se

TOURISM VOCABULARY

rent



www.enjoy-language.se

TOURISM VOCABULARY

refund



www.enjoy-language.se

TOURISM VOCABULARY

nice



www.enjoy-language.se



TOURISM VOCABULARY CARDS

TOURISM VOCABULARY

bad



www.enjoy-language.se

TOURISM VOCABULARY

beautiful



www.enjoy-language.se

TOURISM VOCABULARY

breezy



www.enjoy-language.se

TOURISM VOCABULARY

cautious



www.enjoy-language.se

TOURISM VOCABULARY

convenient



www.enjoy-language.se

TOURISM VOCABULARY

deep



www.enjoy-language.se

TOURISM VOCABULARY

difficult



www.enjoy-language.se

TOURISM VOCABULARY

exhausting



www.enjoy-language.se

TOURISM VOCABULARY

expensive



www.enjoy-language.se

TOURISM VOCABULARY

fantastic



www.enjoy-language.se

TOURISM VOCABULARY

foggy



www.enjoy-language.se

TOURISM VOCABULARY

hot



www.enjoy-language.se

TOURISM VOCABULARY

inexpensive



www.enjoy-language.se

TOURISM VOCABULARY

mountainous



www.enjoy-language.se

TOURISM VOCABULARY

quick



www.enjoy-language.se





TOURISM VOCABULARY CARDS 1

TOURISM VOCABULARY



www.enjoy-language.se

TOURISM VOCABULARY



www.enjoy-language.se

TOURISM VOCABULARY



www.enjoy-language.se

TOURISM VOCABULARY



www.enjoy-language.se

TOURISM VOCABULARY



www.enjoy-language.se

TOURISM VOCABULARY



www.enjoy-language.se

TOURISM VOCABULARY



www.enjoy-language.se

TOURISM VOCABULARY



www.enjoy-language.se

TOURISM VOCABULARY



www.enjoy-language.se

TOURISM VOCABULARY



www.enjoy-language.se

TOURISM VOCABULARY



www.enjoy-language.se

TOURISM VOCABULARY



www.enjoy-language.se

TOURISM VOCABULARY



www.enjoy-language.se

TOURISM VOCABULARY



www.enjoy-language.se

TOURISM VOCABULARY



www.enjoy-language.se



Enjoy Language within Tourism www.enjoy-language.se





TOURISM VOCABULARY CARDS 1

TOURISM VOCABULARY



www.enjoy-language.se

TOURISM VOCABULARY



www.enjoy-language.se

TOURISM VOCABULARY



www.enjoy-language.se

TOURISM VOCABULARY



www.enjoy-language.se

TOURISM VOCABULARY



www.enjoy-language.se

TOURISM VOCABULARY



www.enjoy-language.se

TOURISM VOCABULARY



www.enjoy-language.se

TOURISM VOCABULARY



www.enjoy-language.se

TOURISM VOCABULARY



www.enjoy-language.se

TOURISM VOCABULARY



www.enjoy-language.se

TOURISM VOCABULARY



www.enjoy-language.se

TOURISM VOCABULARY



www.enjoy-language.se

TOURISM VOCABULARY



www.enjoy-language.se

TOURISM VOCABULARY



www.enjoy-language.se

TOURISM VOCABULARY



www.enjoy-language.se



Enjoy Language within Tourism www.enjoy-language.se





TOURISM VOCABULARY CARDS 1

TOURISM VOCABULARY



www.enjoy-language.se

TOURISM VOCABULARY



www.enjoy-language.se

TOURISM VOCABULARY



www.enjoy-language.se

TOURISM VOCABULARY



www.enjoy-language.se

TOURISM VOCABULARY



www.enjoy-language.se

TOURISM VOCABULARY



www.enjoy-language.se

TOURISM VOCABULARY



www.enjoy-language.se

TOURISM VOCABULARY



www.enjoy-language.se

TOURISM VOCABULARY



www.enjoy-language.se

TOURISM VOCABULARY



www.enjoy-language.se

TOURISM VOCABULARY



www.enjoy-language.se

TOURISM VOCABULARY



www.enjoy-language.se

TOURISM VOCABULARY



www.enjoy-language.se

TOURISM VOCABULARY



www.enjoy-language.se

TOURISM VOCABULARY



www.enjoy-language.se



Enjoy Language within Tourism www.enjoy-language.se



STRENGTHS

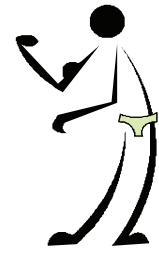

WEAKNESSES



OPPORTUNITIES

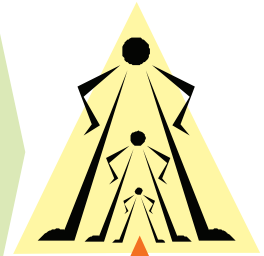

THREATS



CULTURAL TOURISM - SWOT ANALYSIS 2

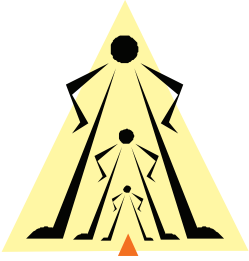

OPPORTUNITIES

STRENGTHS

THREATS

WEAKNESSES

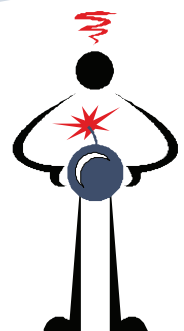

CRUISE SHIP TRAVEL SEASONS

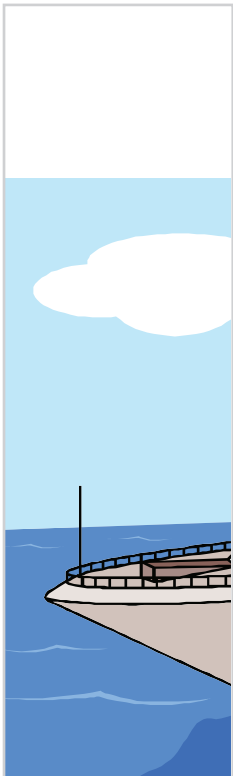

January
February

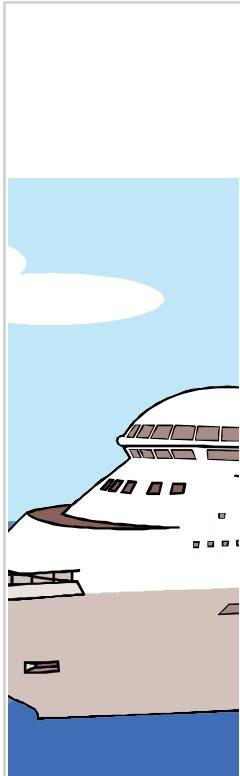

March
April

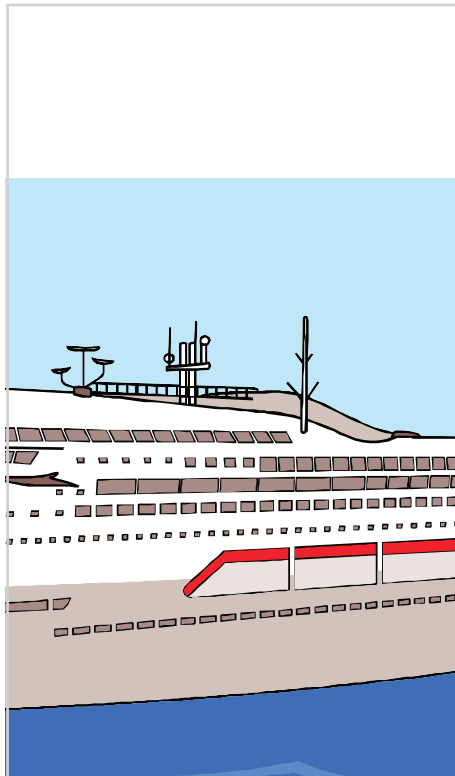

May
June
July
August

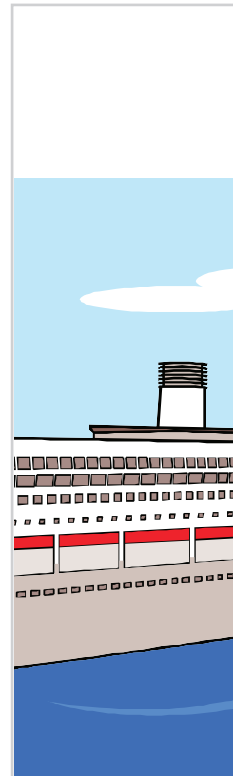

September
October

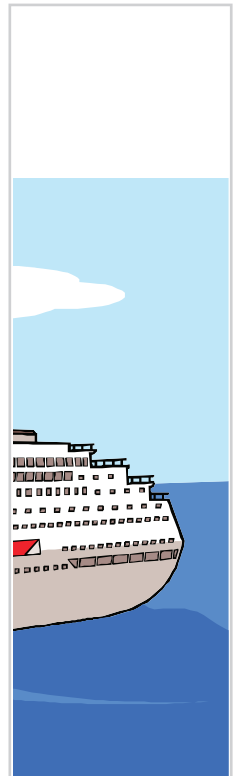

November
December





ACTIVITY TOURISM - SAIL AWAY

PAIR CROSSWORD A

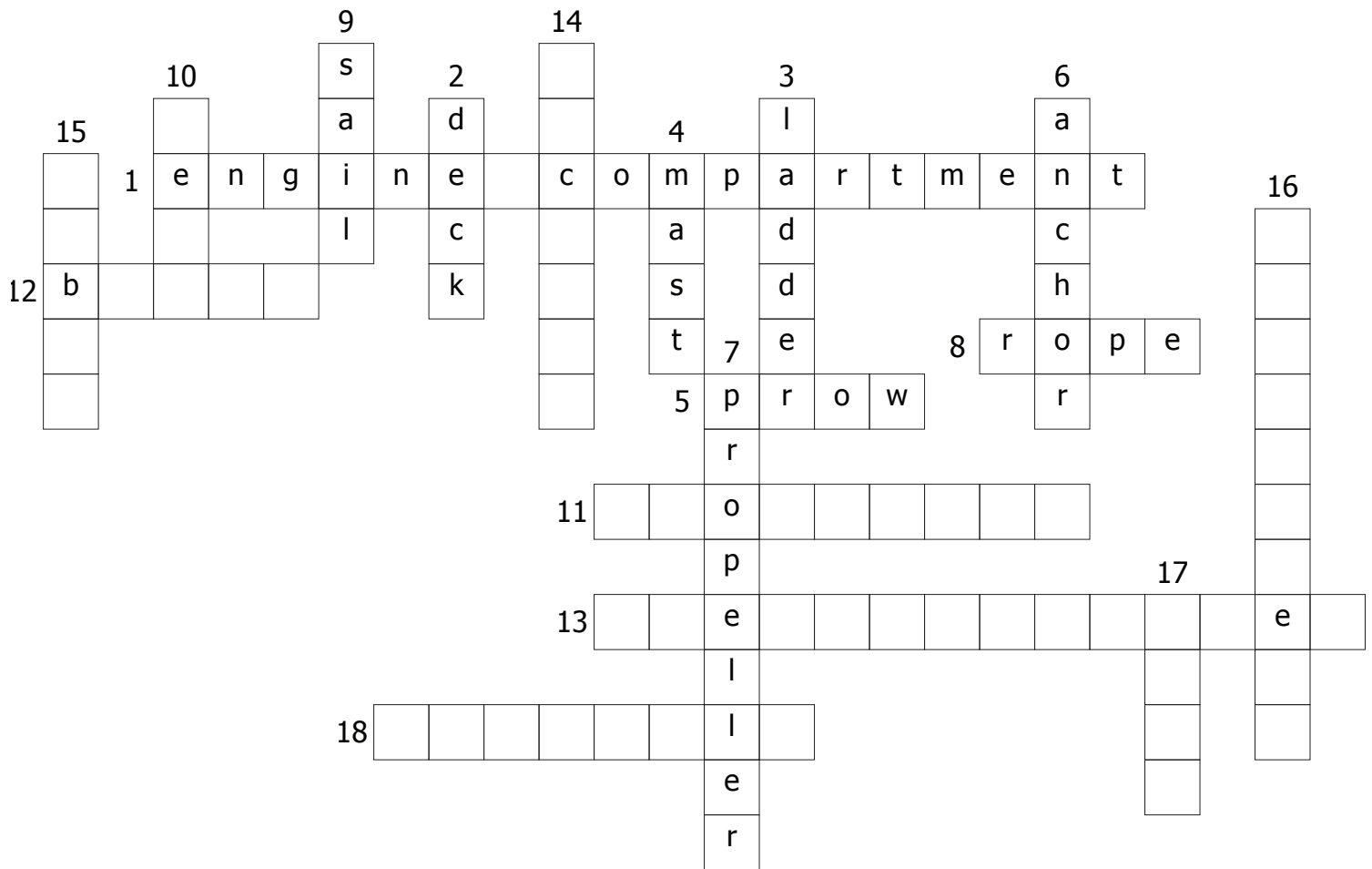

1. A below-decks area where the propulsion equipment is mounted.
2. A platform extending from one side of a ship to the other and forming the floor.
3. A set of rungs or steps between two long supports, for climbing up or down.
4. A long upright pole especially for carrying the sails of a ship, an aerial, flag.
5. The front part of a ship; the bow.
6. A heavy object attached to a vessel by a cable or rope and cast overboard to keep the vessel in place.
7. A mechanical device that rotates to push against air or water.
8. A thick cord, made by twisting together lengths of hemp, nylon.
9. A sheet of strong cloth spread to catch the wind, by which a ship is driven forward.





ACTIVITY TOURISM - SAIL AWAY

PAIR CROSSWORD B

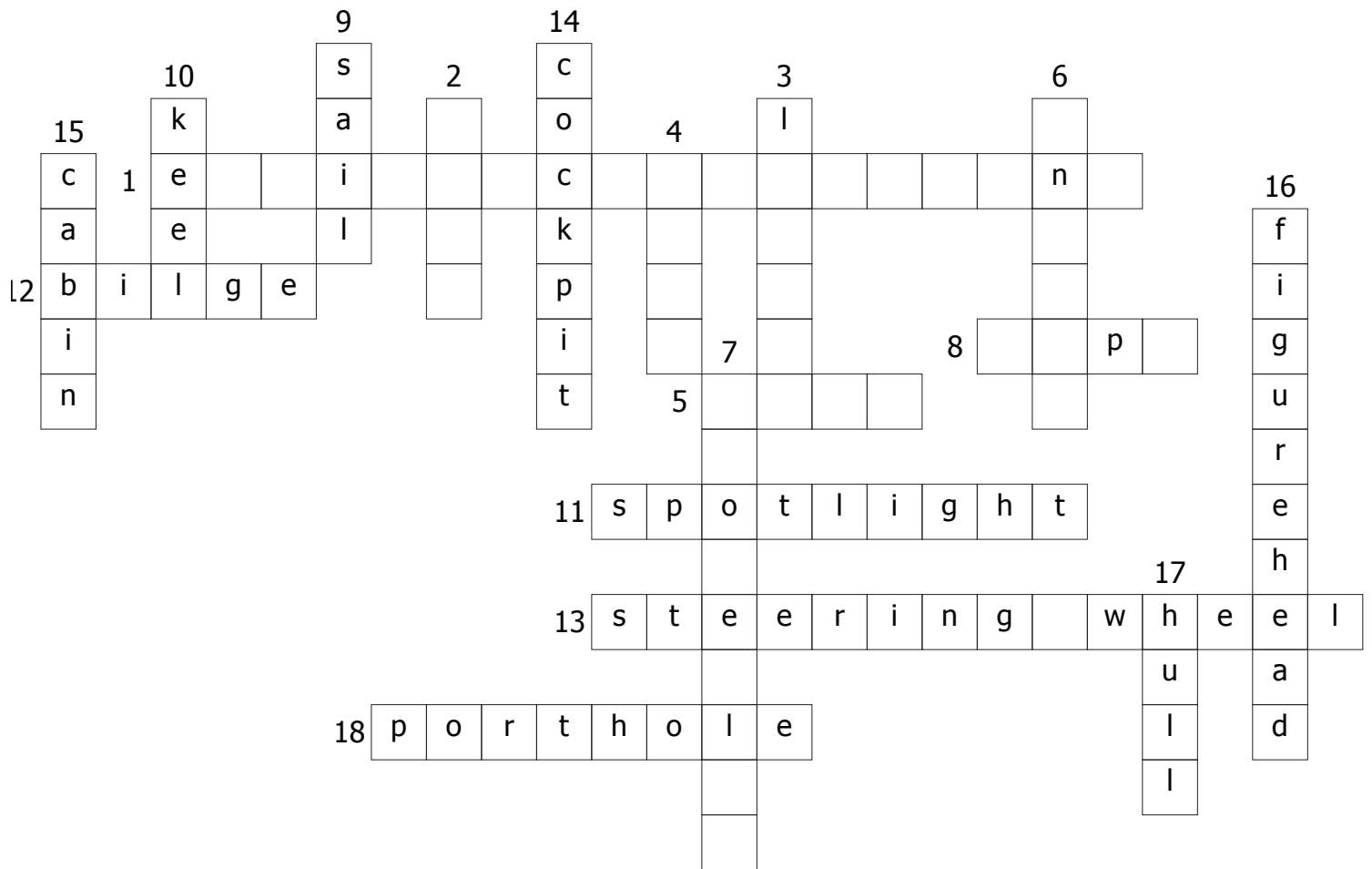

10. The long supporting piece of a ship's frame that lies lengthwise along the bottom.
11. An intense light with a focused beam, often mounted above the wheelhouse to aid in navigating a marked seaway.
12. The part of the bottom of a ship where the relatively flat shape begins curving up to form the topsides.
13. A spoked wheel on the steering shaft allowing a good purchase and a mechanical advantage enabling the helmsman to turn and steer the vessel.
14. An enclosed or recessed area towards the stern of a small vessel from which it is steered.
15. A compartment below offering accommodations for passengers and crew.
16. A piece of inspiring statuary mounted outboard of the bow of a ship just under the bowsprit. Usually this is the figure of a woman portraying some meaning to the mission or beliefs of the ship's company, and which symbolically leads them on their voyage.
17. The body of a ship between the deck and the keel.
18. A small, usually round, window in a ship.





Introduction and hotel location



Rooms & Suites

Guest Services

Restaurants & Bars

Health & Fitness

« This week's special »



YOUR

HOTEL



Introduction and hotel location

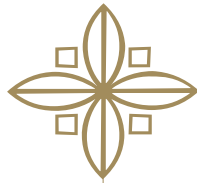

Rooms & Suites

Guest Services

Restaurants & Bars

Health & Fitness

« This week's special »



YOUR

HOTEL



ROCKY'S

STARTERS - APPETIZERS - SOUPS

- Starters**
- Nachos** 9.75
Black olives, tomatoes, green pepper, jalapeño, onions, nacho cheese, sour cream, meat sauce, salsa
- Mozza Chips & Dip** 6.25
Chicken Wings 9.00
Mild, medium, hot, honey&garlic, cola
- Bruschetta** 7.25
Mushroom, pepper&feta, salami&pesto, hummus with tomato
- Deep Fried Veggies** 6.25
Onion rings, pepperoni, mushroom, potatoes, everything
- Danishes** 4.25
Sweet cheese, lemon, cherry
- Muffins** 3.50
Blueberry, corn, Double Chocolate Chunk, Carrot Nut, Raisin Bran, Cranberry Walnut, Banana Walnut, Apple Spice, Pumpkin
- Salads** 6.75
Greek salad, Fresh garden salad, Caesar salad
- Breads** 4.75
Garlic bread with cheese (mozzarella, cheddar or feta)
- Soups** 6.95
Clam Chowder 6.50
French Onion Soup

SPECIALTIES

- American breakfast** 21.50
Two eggs any style, toasted brioche, bacon or country sausage, your choice of pastry, juice and coffee.
- Two Eggs Any Style** 12.50
Two eggs, toasted brioche and your choice of bacon or country sausage.
- Grilled chicken gorgonzola** 14.95
Grilled Chicken sprinkled with Blue Cheese, topped with Onions
- Classic tuna salad** 9.50
Tuna Salad with Tomato on Toasted Multi-Grain Bread
- Waffles of the house** 11.00
Waffles with fresh fruit, syrup and whipped butter.
- Old Fashioned Pork Chop Dinner** 8.25
Pork Chops served the old fashioned way with homemade mashed potatoes, stuffing, gravy and applesauce
- Salmon Baguette** 13.50
Smoked salmon with petite baguette, cream cheese, red onions, tomato and capers.

PIZZA AND PASTA - BURGERS - BEVERAGES

- Pizza Rocky's (pepperoni, mushrooms, mozzarella) 13.50
BBQ Chicken Pizza 12.00
Spaghetti and Meat Sauce 11.50
Lasagna & Side Caesar 12.50
- BURGERS** 9.50
Rocky's Bacon Cheeseburger with Fries 10.50
100% Pure Beef with Fries 9.00
Crispy Chicken Burger
- BEVERAGES** **Bottle** **Draft**
Rocky's Root Beer 4.50 6.50
Rocky's Bottled Soda (g rape/orange) 3.50
Large Bottled Water (still/sparkling) 3.50
Juice (cranberry/pineapple/o range) 3.00

HOT DRINKS

- Coffee 3.50
Cafe Au Lait 3.50
Mulled wine (red/white) 3.50
Lemon Iced Tea 3.50
Fruit Punch 3.50
English Breakfast 3.50
Hot Chocolate 3.50
- Iced Coffee 3.00
Iced Latte 4.25
Iced Mocha 4.75
Iced Lemon Tea 4.75
- Bellini 8.50
Mimosa 8.50
Bloody Marie 9.00
Espresso Martini 9.00



ROCKY'S

PIZZA AND PASTA - BURGERS - BEVERAGES

BURGERS

BEVERAGES

HOT DRINKS



STARTERS - APPETIZERS - SOUPS

Starters

Soups

SPECIALTIES



LEISURE TOURISM COMIC STRIPS STORY 1

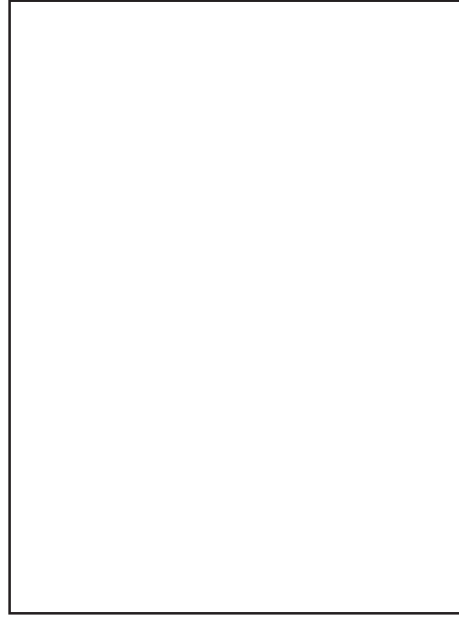
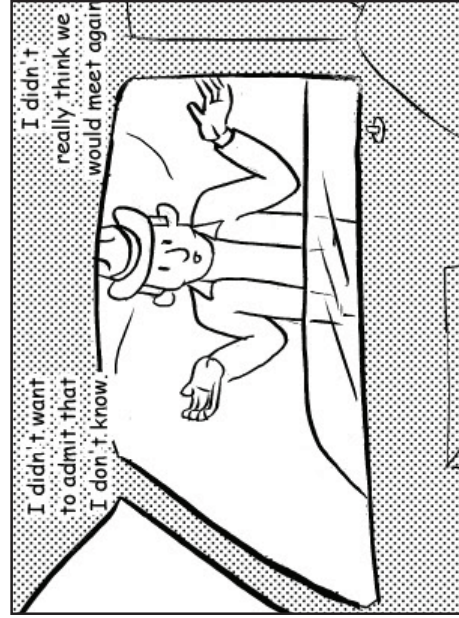
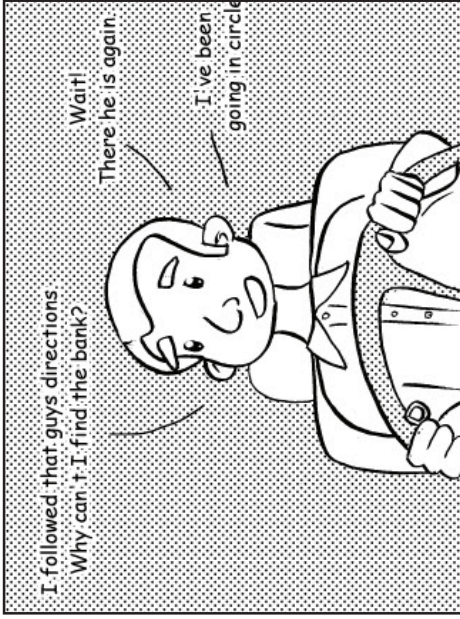
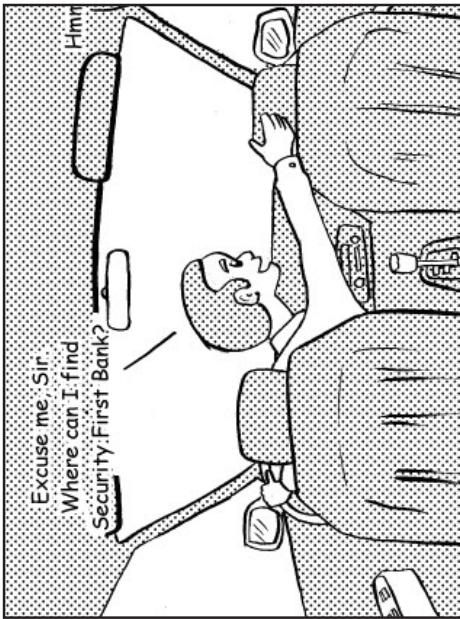

Source of the images: ESLComics - Driving Directions by Sterling Daniels <http://eslcomics.com/>



Enjoy Language within Tourism www.enjoy-language.se

LEISURE TOURISM COMIC STRIPS STORY 2

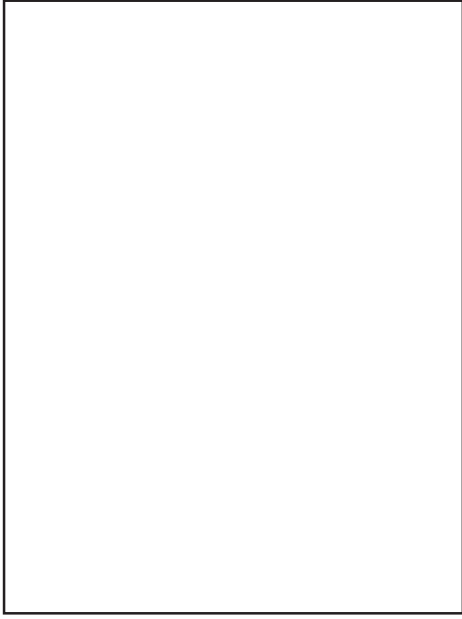

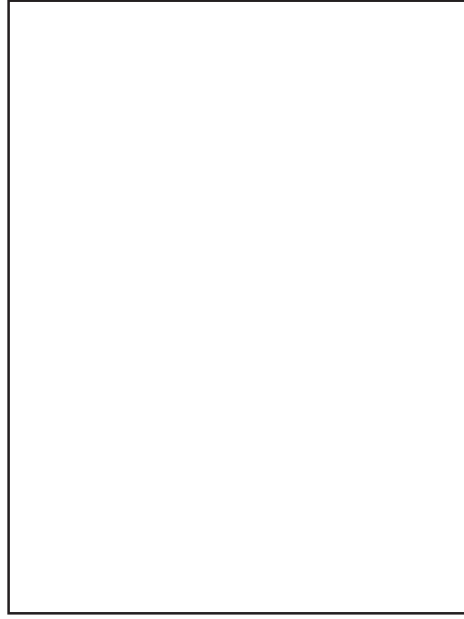

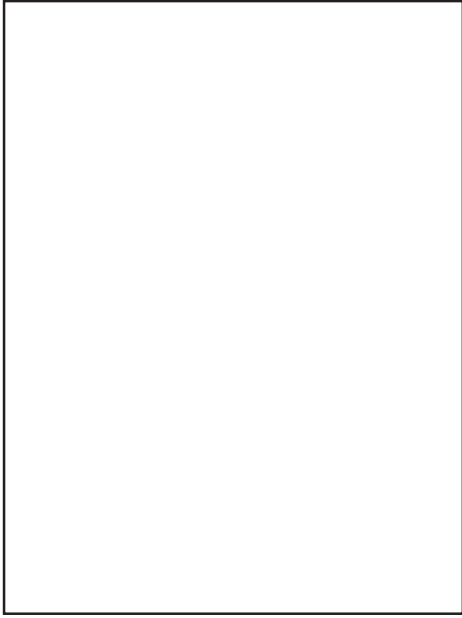

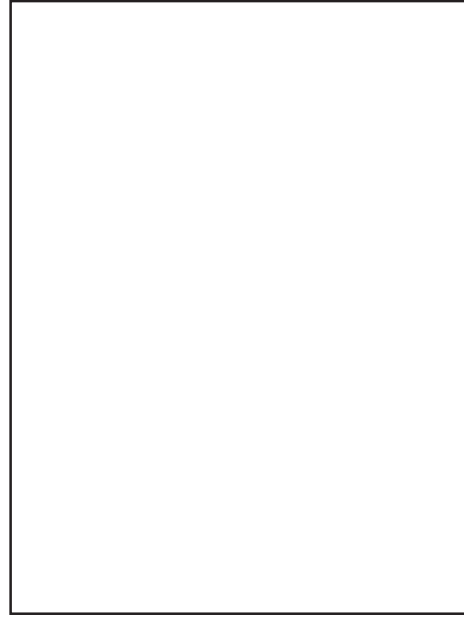

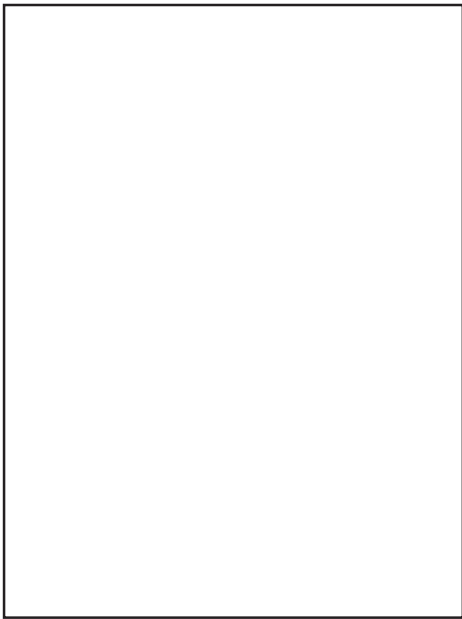

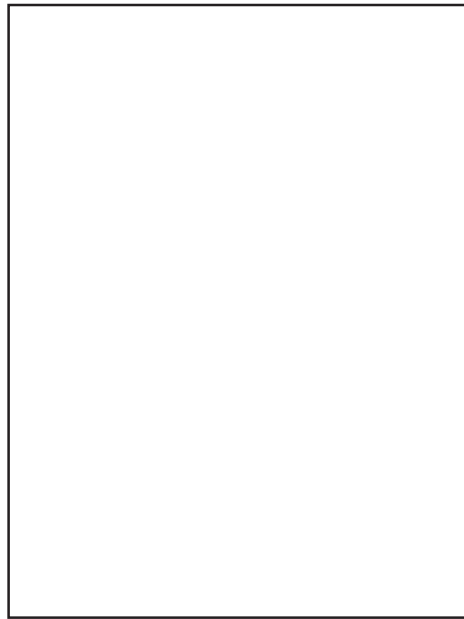

Source of the images: ESLComics - Driving Directions by Sterling Daniels <http://eslcomics.com/>



Enjoy Language within Tourism www.enjoy-language.se

TOURISM DEBATE CARDS 1



ENJOY LANGUAGE

BE CAREFUL IT MIGHT BE AGAINST THE LAW!

www.enjoy-language.se

A project financed under the Life Long Learning Programme (LLP-Ldv/TOI/SE/11/1383 - 2011-1-SE1-LEO05-08376)

BE CAREFUL IT MIGHT BE AGAINST THE LAW!

In California it is illegal to set a mouse trap without a hunting license.



www.enjoy-language.se

BE CAREFUL IT MIGHT BE AGAINST THE LAW!

In Finland, taxi drivers must pay royalties if they play music in their cars for paying customers.



www.enjoy-language.se

BE CAREFUL IT MIGHT BE AGAINST THE LAW!

The head of any dead whale found on the British coast is legally the property of the king.



www.enjoy-language.se

BE CAREFUL IT MIGHT BE AGAINST THE LAW!

In Saudi Arabia, it is illegal for a woman to appear in public without a male relative or guardian. Women aren't allowed to drive, either.



www.enjoy-language.se

BE CAREFUL IT MIGHT BE AGAINST THE LAW!

Unless you're chewing gum with therapeutic value, it is banned in Singapore under the "Regulation of Imports and Exports (Chewing Gum) Regulations."



www.enjoy-language.se

BE CAREFUL IT MIGHT BE AGAINST THE LAW!

Noisy sandals are outlawed on the Isle of Capri.



www.enjoy-language.se

BE CAREFUL IT MIGHT BE AGAINST THE LAW!

Drunk drivers can be executed by firing squad in San Salvador. If you want to legally drink and drive, go to the US Virgin Islands instead.



www.enjoy-language.se

TOURISM DEBATE CARDS 2

BE CAREFUL IT MIGHT BE AGAINST THE LAW!

It is illegal to leave your house in Thailand if you are not wearing underwear.



www.enjoy-language.se

BE CAREFUL IT MIGHT BE AGAINST THE LAW!

In Canada, any public debt over 25 cents cannot be paid in pennies.



www.enjoy-language.se

BE CAREFUL IT MIGHT BE AGAINST THE LAW!

The mayor of Eraclea (a town near Venice) has banned the building of sandcastles and the collecting of sea shells.



www.enjoy-language.se

BE CAREFUL IT MIGHT BE AGAINST THE LAW!

A pillow is considered a "passive weapon" in Germany, so it may be a good idea to keep it locked in your hotel safe while you're out.



www.enjoy-language.se

BE CAREFUL IT MIGHT BE AGAINST THE LAW!

It is illegal to endanger a moving train by standing a vehicle on the tracks in Prince William County in Virginia, USA.



www.enjoy-language.se

BE CAREFUL IT MIGHT BE AGAINST THE LAW!

It is a legal requirement in both Denmark and the Czech Republic to drive with your headlights on at all times.



www.enjoy-language.se

BE CAREFUL IT MIGHT BE AGAINST THE LAW!

In London, UK, it is illegal to flag down a taxi if you have the plague.



www.enjoy-language.se

BE CAREFUL IT MIGHT BE AGAINST THE LAW!

It is forbidden to carry rabid dogs and corpses in a city cab in London, UK.



www.enjoy-language.se

TOURISM DEBATE CARDS 3

BE CAREFUL IT MIGHT BE AGAINST THE LAW!

It's illegal to feed pigeons in Venice, Italy. The pigeon poop pollutes the local buildings and a fine of around 50-600 USD is enough to deter you.



www.enjoy-language.se

BE CAREFUL IT MIGHT BE AGAINST THE LAW!

In California, anyone caught selling a "smoothie" that has lumps is breaking the law.



www.enjoy-language.se

BE CAREFUL IT MIGHT BE AGAINST THE LAW!

In Kentucky, it's illegal to paint your lawn red.



www.enjoy-language.se

BE CAREFUL IT MIGHT BE AGAINST THE LAW!

In New York, the penalty for jumping off a building is: Death.



www.enjoy-language.se

BE CAREFUL IT MIGHT BE AGAINST THE LAW!

In California it is illegal for a vehicle without a driver to exceed 60 miles per hour.



www.enjoy-language.se

BE CAREFUL IT MIGHT BE AGAINST THE LAW!

In Devon, Texas, it is against the law to make furniture while you are nude.



www.enjoy-language.se

BE CAREFUL IT MIGHT BE AGAINST THE LAW!

Dirty cars spotted in Moscow can end up with a 100 USD fine, although how dirty isn't defined.



www.enjoy-language.se

BE CAREFUL IT MIGHT BE AGAINST THE LAW!

No kissing is allowed in England or France (train station platforms). The law is designed to stop train delays.



www.enjoy-language.se

TOURISM DEBATE CARDS 4

BE CAREFUL IT MIGHT BE AGAINST THE LAW!

You cannot die in the Houses of Parliament in the UK.



www.enjoy-language.se

BE CAREFUL IT MIGHT BE AGAINST THE LAW!

In Denmark, one cannot be charged for a meal at an inn unless that person (in his or her own opinion) is "full".



www.enjoy-language.se

BE CAREFUL IT MIGHT BE AGAINST THE LAW!

Blogging is forbidden in Vietnam, well at least chatting in forums or blogging about the Vietnamese government is strictly forbidden.



www.enjoy-language.se

BE CAREFUL IT MIGHT BE AGAINST THE LAW!

Picking one's nose on the Sabbath is highly illegal throughout Israel.



www.enjoy-language.se

BE CAREFUL IT MIGHT BE AGAINST THE LAW!

In Thailand, no one is allowed to step on any of the nation's currency.



www.enjoy-language.se

BE CAREFUL IT MIGHT BE AGAINST THE LAW!

In Oklahoma, you can be arrested for making ugly faces at a dog.



www.enjoy-language.se

BE CAREFUL IT MIGHT BE AGAINST THE LAW!

In Salt Lake County, Utah, it's illegal to walk down the street carrying a violin in a paper bag.



www.enjoy-language.se

BE CAREFUL IT MIGHT BE AGAINST THE LAW!

In Florida men seen publicly in any kind of strapless gown can be fined.



www.enjoy-language.se

TOURISM DEBATE CARDS 5

BE CAREFUL IT MIGHT BE AGAINST THE LAW!

In Pennsylvania, it's against the law to tie a dollar bill on a string on the ground and pull it away when someone tries to pick it up.



www.enjoy-language.se

BE CAREFUL IT MIGHT BE AGAINST THE LAW!

In Massachusetts, it is illegal to go to bed without first having a bath. (However, another law prohibits bathing on Sunday).



www.enjoy-language.se

BE CAREFUL IT MIGHT BE AGAINST THE LAW!

In Samoa, it's a crime to forget your own wife's birthday.



www.enjoy-language.se

BE CAREFUL IT MIGHT BE AGAINST THE LAW!

In England, it is an act of treason to place a postage stamp bearing the Queen upside down.



www.enjoy-language.se

BE CAREFUL IT MIGHT BE AGAINST THE LAW!

In Sedona, Ariz., it's illegal to lie about your astrological sign.



www.enjoy-language.se

BE CAREFUL IT MIGHT BE AGAINST THE LAW!

In New Jersey, answering a traffic cop who asks "Do you know why I pulled you over?" by saying, "If you don't know, I'm not going to tell you" is an automatic \$300 fine.



www.enjoy-language.se

BE CAREFUL IT MIGHT BE AGAINST THE LAW!

In Arkansas, it's illegal for a woman getting married for the second time to wear a white wedding gown.



www.enjoy-language.se

BE CAREFUL IT MIGHT BE AGAINST THE LAW!

In Portugal, it's against the law to pee in the ocean.



www.enjoy-language.se

TOURISM DEBATE CARDS 6

BE CAREFUL IT MIGHT BE AGAINST THE LAW!

In the days of Sparta, if you were male you legally had to consume 2 pounds of meat a day.



www.enjoy-language.se

BE CAREFUL IT MIGHT BE AGAINST THE LAW!

In Bermuda, private cars were illegal until 1948



www.enjoy-language.se

BE CAREFUL IT MIGHT BE AGAINST THE LAW!

In Denmark it is not against the law to escape from prison.



www.enjoy-language.se

BE CAREFUL IT MIGHT BE AGAINST THE LAW!

In Denmark, you legally have to check under your car for children asleep before you start it.



www.enjoy-language.se

BE CAREFUL IT MIGHT BE AGAINST THE LAW!

In Switzerland, it use to be illegal to slam a car door.



www.enjoy-language.se

BE CAREFUL IT MIGHT BE AGAINST THE LAW!

2000 years ago in Rome, Julius Caesar banned chariots from Rome city centre to ease congestion.



www.enjoy-language.se

BE CAREFUL IT MIGHT BE AGAINST THE LAW!

In Turkey, it was illegal to drink coffee during the 16th and 17th century. It was punishable by death.



www.enjoy-language.se

BE CAREFUL IT MIGHT BE AGAINST THE LAW!

In Seville, Spain, in 1983, a German Sheppard was arrested for stealing woman's handbags.



www.enjoy-language.se

TOURISM DEBATE CARDS 7

BE CAREFUL IT MIGHT BE AGAINST THE LAW!

In Stelvio, Italy, 1519, a gang of moles that had damaged crops was given an arrest warrant. They never showed up for court.



www.enjoy-language.se

BE CAREFUL IT MIGHT BE AGAINST THE LAW!

In 1471 Switzerland, the Cockerel was found guilty of "In defiance of natural law" by laying an egg. It was executed.



www.enjoy-language.se

BE CAREFUL IT MIGHT BE AGAINST THE LAW!

It was once illegal to own a pet dog in Iceland.



www.enjoy-language.se

BE CAREFUL IT MIGHT BE AGAINST THE LAW!

In 1979 Iraq banned karate movies.



www.enjoy-language.se

BE CAREFUL IT MIGHT BE AGAINST THE LAW!

The only country in the world to never have censorship for adult films is Belgium.



www.enjoy-language.se

BE CAREFUL IT MIGHT BE AGAINST THE LAW!

Due to lack of pants, Donald Duck cartoons were banned in Finland.



www.enjoy-language.se

BE CAREFUL IT MIGHT BE AGAINST THE LAW!

In 1935 Romania, for fear of scaring young children, Mickey Mouse was banned.



www.enjoy-language.se

BE CAREFUL IT MIGHT BE AGAINST THE LAW!

Until 1984 in Belgium, you had to choose your child's name off a list of 1500.



www.enjoy-language.se

TOURISM DEBATE CARDS 8

BE CAREFUL IT MIGHT BE AGAINST THE LAW!

In Bangladesh you face prison time for cheating at school.



www.enjoy-language.se

BE CAREFUL IT MIGHT BE AGAINST THE LAW!

In Burma it is against the law to access the Internet. Anyone doing so faces prison.



www.enjoy-language.se

BE CAREFUL IT MIGHT BE AGAINST THE LAW!

In Switzerland you legally have to live within 200m of a nuclear bomb shelter.



www.enjoy-language.se

BE CAREFUL IT MIGHT BE AGAINST THE LAW!

In Milan, Italy, unless going to a hospital or funeral, you have to smile or face a fine.



www.enjoy-language.se

BE CAREFUL IT MIGHT BE AGAINST THE LAW!

In Paraguay you can legally duel, as long as both participating players are blood donors.



www.enjoy-language.se

BE CAREFUL IT MIGHT BE AGAINST THE LAW!

In Wetaskiwin, Alberta, Canada, in 1917, tying a male horse next to a female horse was illegal.



www.enjoy-language.se

BE CAREFUL IT MIGHT BE AGAINST THE LAW!

Hundreds of years ago you were instantly executed if you tried to leave Japan.



www.enjoy-language.se

BE CAREFUL IT MIGHT BE AGAINST THE LAW!

During World War I if you were found to be homosexual you were executed.



www.enjoy-language.se

TOURISM DEBATE CARDS 9

BE CAREFUL IT MIGHT BE AGAINST THE LAW!

In 1837, Egypt banned male belly dancing as it caused mass rioting.



www.enjoy-language.se

BE CAREFUL IT MIGHT BE AGAINST THE LAW!

In Afghanistan the Taliban banned women from wearing white socks, for fear men might find them attractive.



www.enjoy-language.se

BE CAREFUL IT MIGHT BE AGAINST THE LAW!

In San Salvador, drunk drivers can be sentenced to death by firing squad.



www.enjoy-language.se

BE CAREFUL IT MIGHT BE AGAINST THE LAW!

In Victoria, Australia after mid day on Sunday, it's illegal to wear pink hot pants.



www.enjoy-language.se

BE CAREFUL IT MIGHT BE AGAINST THE LAW!

In Victoria, Australia, you need a licensed electrician to change a light bulb.



www.enjoy-language.se

BE CAREFUL IT MIGHT BE AGAINST THE LAW!

In Ohio, getting a fish drunk is against state law.



www.enjoy-language.se

BE CAREFUL IT MIGHT BE AGAINST THE LAW!

In Vermont, for a woman to wear false teeth she first must get written permission from her husband.



www.enjoy-language.se

BE CAREFUL IT MIGHT BE AGAINST THE LAW!

In Eureka, Nevada, if you have a moustach it's against the law for you to kiss a woman.



www.enjoy-language.se

TOURISM DEBATE CARDS 10

BE CAREFUL IT MIGHT BE AGAINST THE LAW!

In Providence, Rhode Island, selling tooth paste and a tooth brush to the same customer on a Sunday is illegal.



www.enjoy-language.se

BE CAREFUL IT MIGHT BE AGAINST THE LAW!

In Texas, if you are going to commit a crime, you legally have to give 24 hours notice to the police.



www.enjoy-language.se

BE CAREFUL IT MIGHT BE AGAINST THE LAW!

In Washington, pretending to have wealthy parents is illegal.



www.enjoy-language.se

BE CAREFUL IT MIGHT BE AGAINST THE LAW!

In Baltimore, Maryland, taking a lion to the cinema is illegal.



www.enjoy-language.se

BE CAREFUL IT MIGHT BE AGAINST THE LAW!

In International Falls, Minnesota, you can be fined if you let your dog chase a cat up a telegraph pole.



www.enjoy-language.se

BE CAREFUL IT MIGHT BE AGAINST THE LAW!

In Massachusetts, your breaking the law if you consume more than 3 sandwiches at a wake.



www.enjoy-language.se

BE CAREFUL IT MIGHT BE AGAINST THE LAW!

In Iowa, horses are breaking the law if they eat a fire hydrant.



www.enjoy-language.se

BE CAREFUL IT MIGHT BE AGAINST THE LAW!

In London, it is illegal to throw a stick for your dog in any park.



www.enjoy-language.se

CULTURAL TOURISM STRANGE HOTEL ROOMS 1



As part of a promotion for its rebranding campaign, Holiday Inn in 2009 constructed a Manhattan hotel room entirely out of key cards. The 400-sq.-ft. room used 200,000 Holiday Inn cards and featured a reception desk, a bed and even a toilet.

Read more: <http://business.time.com/2012/08/01/the-worlds-nine-most-interesting-hotel-rooms/#ixzz25xIZqGvt>



CULTURAL TOURISM STRANGE HOTEL ROOMS 2



You'd need more than a sweet tooth to handle a night in the Godiva Chocolate Suite. Placed in New York City's Bryant Park Hotel in 2008 and 2009 as part of a Valentine's Day giveaway by chocolate maker Godiva, the hotel room featured chocolate walls, paintings and chandeliers. Luckily, no one lit the logs in the chocolate fireplace.

Read more: <http://business.time.com/2012/08/01/the-worlds-nine-most-interesting-hotel-rooms/#ixzz25xlmzPly>





CULTURAL TOURISM STRANGE HOTEL ROOMS 3



Just how wintry do you want to get? This Finnish hotel offers log cabins, but you can also stay in a heated glass igloo in which the glass won't fog up and ruin your view of the Northern Lights. If you're feeling really adventurous, you can stay in a legitimate snow igloo. Don't expect luxury. You'll be provided with a down sleeping bag, woolen socks and a hood.

Read more: <http://business.time.com/2012/08/01/the-worlds-nine-most-interesting-hotel-rooms/#ixzz25xJ1Y5MI>



CULTURAL TOURISM STRANGE HOTEL ROOMS 4



This capsule hotel located in Kyoto takes efficiency to a new level. Guests are given seven hours to sleep, one hour to shower and an hour to relax, then it's out the door so the next guest can sleep. Fine linens and complimentary slippers make this a luxury option in the capsule-hotel market.

Read more: <http://business.time.com/2012/08/01/the-worlds-nine-most-interesting-hotel-rooms/#ixzz25xJBbm4f>



CULTURAL TOURISM HOTEL PRANKS 1

AROUND	UNDER	INSIDE	OUT OF
BEHIND	IN	INTO	TO
IN	BEHIND	INTO	IN
FROM	FROM	NEXT TO	UNDERNEATH
IN	IN	ON	IN

Comedian Bert Kreischer shocks hotel staff

IF you thought you were a bad hotel guest for failing to wash up or make your bed then think again, a comedian has been leaving some “creepy” surprises _____ that are designed to truly shock hotel staff.

A frequent traveller, funnyman Bert Kreischer has been giving hotel rooms _____ the world “disturbing” makeovers by leaving items _____ or re-arranging them so that they appear to take on spooky forms.

Some of the creepy scenes by Mr Kreischer appear to show a man hiding _____ a food cart, a toilet transformed with fangs dripping with blood and a stuffed shirt _____ a fridge. In other rooms a sheet hangs _____ a window like a rope and toilet paper is made _____ the outline of a body _____ a crime scene. Legs are seen poking out _____ underneath a bed, curtains and even from _____ a television mounted _____ a wall.

Mr Kreischer says his goal is to leave each room in a “semi-disturbing manner” – and he may well have succeeded if images of his creations posted on his Twitter page are anything to go by. “I will pace a room with a pillow person _____ the bed, trying to figure out the best way to make the face ‘creepy’, but not ‘too creepy,’” Mr Kreischer said.

Mr Kreischer said that he began the hotel pranks _____ a hotel in San Antonio, Texas in a bid to draw attention away from what he was really getting up to in his room. “I realised that if a maid was insightful enough she could tell exactly what I had done _____ my hotel room and she might think less of me,” he said.

“So I tried to throw her off my trail by putting an ironing board in the bathroom _____ a pillow encrusted toilet...and that started it all.”

Mr Kreischer said that he has not seen how hotel staff react _____ his “creations” but that he makes sure he always compensates them for their trouble. “I am long gone by the time anyone _____ the hotel sees my “art”, but I always leave a generous tip and never destroy anything or create anything that would be a hassle to put back together _____ a matter of seconds.”

So which hotels were the most fun to redecorate?

“Hyatts and Hiltons offer the most amount of stuff _____ the room for you to create with... Holiday Inns and Red Roof Ins are pretty bare bones and you end up having to go _____ your suit case for props, but mostly all the props are the same... which makes it tough to come up with new ones.”

Mr Kreischer is using the hotel hijinks pictures to draw attention to his new show Bert the Conqueror. He asked people to come up with “hilarious” captions for images of the pranks uploaded to the website.

Source: <http://www.news.com.au/travel/news/is-this-the-worst-hotel-guest-ever/story-e6frfq80-1226041632612>



Comedian Bert Kreischer shocks hotel staff

IF you thought you were a bad hotel guest for failing to wash up or make your bed then think again, a comedian has been leaving some “creepy” surprises **behind** that are designed to truly shock hotel staff.

A frequent traveller, funnyman Bert Kreischer has been giving hotel rooms **around** the world “disturbing” makeovers by leaving items **behind** or re-arranging them so that they appear to take on spooky forms.

Some of the creepy scenes by Mr Kreischer appear to show a man hiding **underneath** a food cart, a toilet transformed with fangs dripping with blood and a stuffed shirt **inside** a fridge. In other rooms a sheet hangs **out of**

a window like a rope and toilet paper is made **into** the outline of a body **in** a crime scene. Legs are seen poking out **from** underneath a bed, curtains and even from **under** a television mounted **on** a wall.

Mr Kreischer says his goal is to leave each room in a “semi-disturbing manner” – and he may well have succeeded if images of his creations posted on his Twitter page are anything to go by. “I will pace a room with a pillow person **in** the bed, trying to figure out the best way to make the face ‘creepy’, but not ‘too creepy,’” Mr Kreischer said.

Mr Kreischer said that he began the hotel pranks **in** a hotel in San Antonio, Texas in a bid to draw attention away from what he was really getting up to in his room. “I realised that if a maid was insightful enough she could tell exactly what I had done **in** my hotel room and she might think less of me,” he said.

“So I tried to throw her off my trail by putting an ironing board in the bathroom **next to** a pillow encrusted toilet...and that started it all.”

Mr Kreischer said that he has not seen how hotel staff react **to** his “creations” but that he makes sure he always compensates them for their trouble. “I am long gone by the time anyone **from** the hotel sees my “art”, but I always leave a generous tip and never destroy anything or create anything that would be a hassle to put back together **in** a matter of seconds.”

So which hotels were the most fun to redecorate?

“Hyatts and Hiltons offer the most amount of stuff **in** the room for you to create with... Holiday Inns and Red Roof Ins a pretty bare bones and you end up having to go **into** your suit case for props, but mostly all the props are the same... which makes it tough to come up with new ones.”

Mr Kreischer is using the hotel hijinks pictures to draw attention to his new show Bert the Conqueror. He asked people to come up with “hilarious” captions for images of the pranks uploaded to the website.

Source: <http://www.news.com.au/travel/news/is-this-the-worst-hotel-guest-ever/story-e6frfq80-1226041632612>



Comedian Bert Kreischer has been playing pranks on hotel staff. Picture: Bert Kreischer



CULTURAL TOURISM HOTEL PRANKS 3

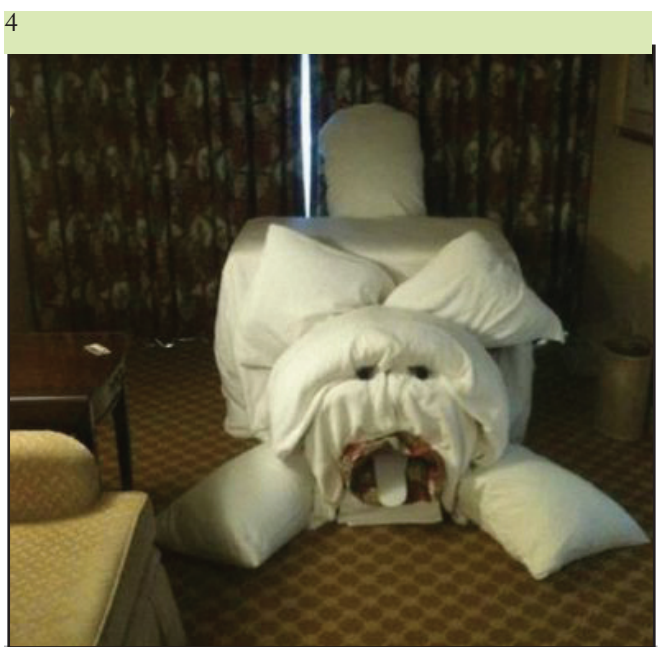
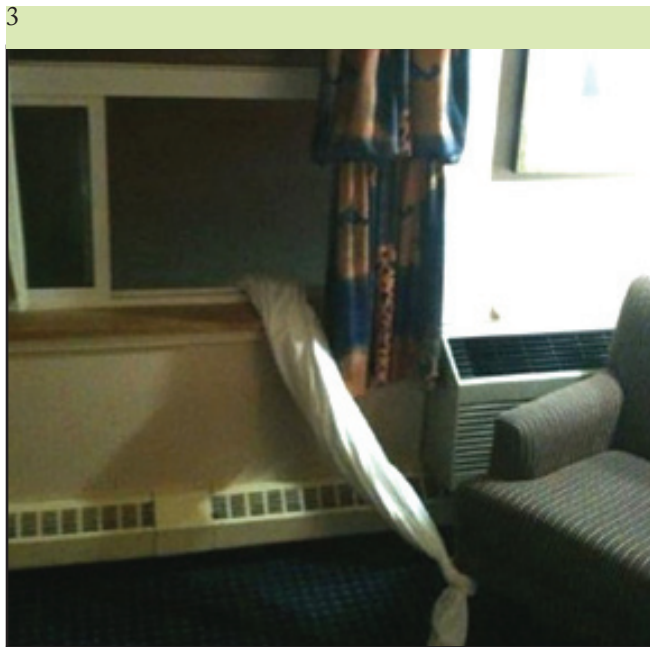
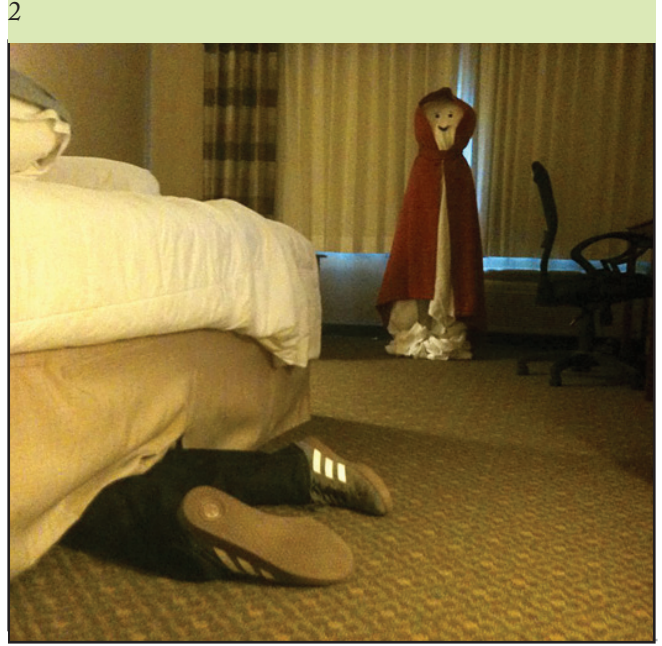
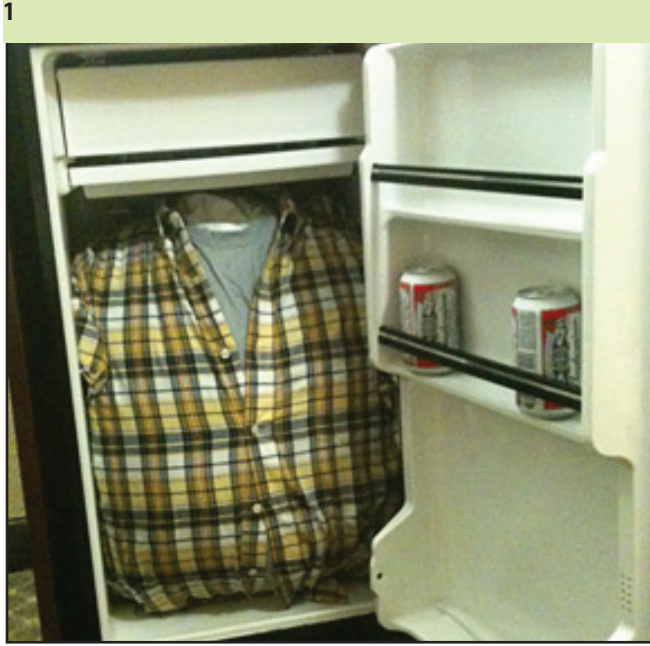

CULTURAL TOURISM HOTEL PRANKS 4

5



6



7



8

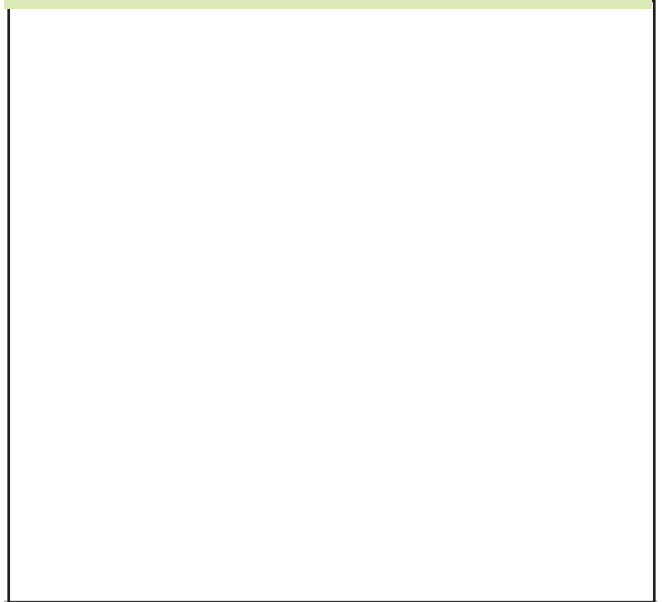



Eww, don't touch that! Confessions of hotel employees

THEY are the hotel secrets you'd probably rather not know. From urine in the whiskey bottles to filthy TV remotes and what not to do with your towel, hotel employees have revealed all in a discussion on website Reddit.com. While we're unable to verify their identities, these tips could come in handy during your next hotel stay.

Think before you drink!

"Check the seals on the things in the minibar. I once had a guest who had drunk the whiskey and then peed in the bottle, closed it, and put it back. I've also seen candy three months past the expiry date."

"Do not use the ice bucket without a liner. It may have been used as a puke receptacle."

Mouthing off

"Always use the disposable cups in the rooms. The glasses/mugs are usually just rinsed in hot water in your bathroom sink."

Don't touch this!

"The remotes for the TV are rarely cleaned."

Cover up

"Use a towel or sheet on the chairs or sofa, a LOT of people sit on them naked. It's nasty but there is often a brown streak on the desk chair that no one think about."

Surprise

"If you book a jacuzzi, be warned, the jet system is often completely clogged up with really nasty gunk."

Avoid or check pretty much everything on the bed

"Duvets (doonas) are NOT meant to be slept on. I know many people are grossed out that they aren't



Anonymous hotel staff spill truths and tips on Reddit thread

always changed but again they are not meant to be used as a blanket... The right thing to do is to fold it and place it on the floor or chair."

"Some maids do not change the sheets (mostly because they don't have enough time in each room and can be fired for taking too long per room). When you check in, check the sheets for creases from being folded and unused. If you have any doubt call housekeeping and ask for fresh sheets on the bed."

'Mattresses WILL be stained, with a lot of stuff. There's no way we could buy a new mattress every time someone bleeds on it, or spills coffee on it, or urinates on it. It wouldn't be practical. So we sponge them down and dry them with hair dryers, or flip them over when it's really bad."

Tasty... ?

"Your breakfast food is likely always been handled in an unsanitary manner during set up (typically desk clerks in lower end hotels.)"

Itchy and scratchy

"Bed bugs are more common than you may think."

Source: <http://www.news.com.au/travel/news/cant-touch-this-confession-of-hotel-employees/story-e6frfq80-1226461550850>



Anonymous hotel staff spill truths and helpful tips

What not to do with your towel

"Maybe everyone knows this, but if you want fresh towels you should put the towels on the floor. If you hang them they will not be changed and you'll have to ask for new ones."

Ask and you shall receive

"I'm a bellman and valet at a resort. I can give you free water bottles, tampons, valet parking, tours, shuttle rides, reservations, dry cleaning, hell even an upgrade to a better room if you just ASK ME. But no one ever does cos they think I'm just a doorman."

"Many things such as fans, heaters and even bathrobes might be something stored in one place in the hotel, if you need something you should ask for it, it's not always in every room."

Beware of scams

"The front desk will NOT call you at an ungodly late hour, if our 'computer crashes' and ask for your credit card information. We will not give you a 50 per cent discount for your cooperation, and no, I would not be calling you if 'there is a line at the front desk, so giving me the information over the phone will be quicker'."

"If you suspect a phone call from the front desk is not the front desk, please make a trip down. People can simply dial random extensions, get direct room lines, and make victims of you."

Don't be afraid to complain

"Any haggling or outright complaining you do will likely get you a discount. I've realised people are more likely to complain at older properties because frankly they're more likely to get it unquestioned. Most won't even bother to go look if it's minor."

Where there's smoke...

"Hotels love charging smokers. It's really not worth even trying. A towel doesn't help."

Safety

"Hotels, even nice ones, attract the worst kind of people. Don't let your kids run around at night, make sure your door is closed properly."

"Always use the deadbolt and/or door chain when in your room."



Anonymous hotel staff spill truths and tips on Reddit thread

The tips come from Reddit users Roslagen, BayHarbourButcher, Druumer89, Avmenza, Cypherd, Jazzminkey, Switchbladesally and Billclinternet.

Source: <http://www.news.com.au/travel/news/cant-touch-this-confession-of-hotel-employees/story-e6frfq80-1226461550850> and <http://www.cnngo.com/explorations/escape/secret-confessions-hotel-employees-661771>



CULTURAL TOURISM HOTEL SECRETS 3

amiable	the last straw	to make up for
company policy	to appease	to make/lodge/file a complaint
customer service desk	to be disinterested	to offer compensation
customer service representative	to be put on hold	to pass the buck
customer-centred	to come up against	to preempt (sb's needs)
empathy	to complain about	to provide
expensive	to deal with	to push sales
high quality	to do away with	to put up with
impeccable	to empathise with	to refocus
impertinent	to exceed (expectations)	to set standards
indifference	to get to the bottom of something	to supply
indifferent	to handle (complaints)	to talk at cross purposes
meticulous	to keep calm	unhelpful
peak times (prime time)		written complaint



HOTEL

COMPLAINT FORM

GIVE AN ACCOUNT OF WHAT HAPPENED, INDICATE THE EXACT TIME AND DATE IF POSSIBLE

NAME AND SIGNATURE

PLACE AND DATE





CULTURAL TOURISM HOTEL SECRETS 4

You may be assured that) this won't happen again.	To make up for this...
Due to the inconvenience we have caused you...	Please accept my/ our (sincere/ sincerest) apologies for...
I (would like to) apologize (wholeheartedly/ unreservedly) (for...)	That will (absolutely) be the last time that happens
I cannot say how sorry I am that...	The delay was due to (circumstances beyond our control/ ...)
There is (really) no excuse for...	The main reason for this was ...
I/ We regret to inform you that...	This was because...
We were very sorry to hear about/ that...	Unfortunately, this was unavoidable as...
I'm (very/ so/ extremely/ truly) sorry (for...)	To compensate you for...
Please forgive me/ us (for...)	We will shortly/ soon be back to normal service
In order to show how sorry we are...	We wonder if you would be willing to accept...
We would like to offer you...	Please accept...
In the future we will...	



HOTEL

COMPLAINT FORM

IN REPLY TO YOUR COMPLAINT DATED

TITLE, NAME AND SIGNATURE

PLACE AND DATE





CULTURAL TOURISM HOTEL SECRETS 5







ON HOLIDAY



Handwriting practice lines consisting of five horizontal dotted lines, each preceded by a small green arrow pointing to the right. A vertical dotted line runs down the left side of these lines, starting from the house icon.





ACTIVITY TOURISM PROFESSION CARDS 1

PROFESSION	WHAT DO THEY DO	PLACE OF WORK



ACTIVITY TOURISM PROFESSION CARDS 2

COMMON INTERVIEW QUESTIONS	SUGGESTIONS ON HOW TO REPLY
Tell me about yourself.	This does not mean "Give me your life story". It's your chance to give an overall impression of who you are. Research the company to get an idea of the skills and experience they're looking for, work those into your response. Make sure you concentrate on who you are, your work experience, and relate everything to show that you would be a great candidate for the position.
What were your main responsibilities in your last job?	Be specific and positive about what you did in your current / previous job. Try to relate them to the job you are being interviewed for.
What is your biggest accomplishment?	Give an example that relates to the job you are interviewing for.
What are your greatest strengths / weaknesses?	Your ability to work well under pressure, prioritizing skills, problem-solving skills, professional expertise, leadership skills, team spirit. Be prepared to give real life examples. Be honest about a specific weakness, but show what you are doing to overcome it.
Why do you want to leave your current job? Why did you leave your last job?	Never say anything bad about your previous employers. Think about leaving for a positive reason.
When can you start?	Straight away. I need to give x weeks notice.
Tell me what you know about this company.	Do your homework before you go to any interview, you should know about the company or business you're going to work for.
Why do you want to work here?	Put some thought into this answer before you have your interview, mention your career goals and highlight forward-thinking goals and career plans.
Do you have any questions?	Yes. Prepare several questions before the interview. You could ask about career / development / training opportunities. Be sure to ask when they'll make their decision.

Source: <http://www.learnenglish.de/vocabulary/jobs.htm> and <http://www.wisebread.com/how-to-answer-23-of-the-most-common-interview-questions%20or%20add%20the%20link%20as%20extra%20material>





ACTIVITY TOURISM PROFESSION CARDS 2

ADJECTIVES TO DESCRIBE SKILLS	WRITE DOWN THE TRANSCRIPT OF AN INTERVIEW
<p>accurate active adaptable broad-minded competent conscientious creative dependable determined diplomatic discreet efficient energetic enterprising enthusiastic experienced fair firm honest innovative logical loyal mature methodical motivated objective outgoing personable pleasant positive practical productive reliable resourceful self disciplined sense of humor sensitive sincere successful tactful trustworthy</p>	

Source: http://esl.about.com/od/businessspeakingkills/a/j_vocabulary.htm



Enjoy Language within Tourism www.enjoy-language.se



ACTIVITY TOURISM - YOU: THE AMBULANCE DRIVER



“C’mon, admit it. You’ve always wanted to drive an ambulance. Flashy lights, playing with the siren, lots of fun, right? It can be, but there is much more to it than simply “driving fast.” Do you have what it takes to operate an ambulance?”

Source of the quizz and more quizzes here: <http://www.funtrivia.com/playquiz/quiz31210823bb1a8.html> Copyright, FunTrivia.com. All Rights Reserved.

1. Congratulations! You have been accepted as a member of your local first aid squad. You have been trained in CEVO (Coaching the Emergency Vehicle Operator) and you anxiously await your first assignment. Soon enough, dispatch transmits the location of your first patient. You hop in the rig with the rest of your crew. What do you do before you release the brake and get underway?

- All of these.
- Make sure that you and your crew are all wearing seatbelts.
- Check that your mirrors are adjusted to provide you with maximum field of vision.
- Adjust your seat and steering wheel to a comfortable position that allows you to reach the controls on your dashboard and center console as well as the gas and brake pedals.

2. You turn on your overhead emergency lights and hit the road. Your fellow crew member is navigating for you. He tells you that you must turn right at the next stop sign 100 feet up ahead. How do you handle this?

- Turn on your sirens and approach the turn. Stop completely, looking both ways for oncoming traffic before turning.
- Completely lose your cool and start babbling that you just can't handle the pressure.
- Approach the turn. Knowing that it is illegal for drivers to ignore an emergency vehicle with lights and sirens on, take the turn as fast as you can without flipping the rig.
- Turn lights and sirens off. Stop at the stop sign and allow other traffic to go through.

3. Your navigator tells you that you must travel several miles on the road you are now on. Traffic is minimal. Weather conditions are good, as are road conditions. The speed limit is 50 mph (80 kmh). How fast will you go?

- Twice the speed limit.
- As fast as possible - around 90 mph (145 km/hr).
- As fast as you want, as long as you have lights and sirens in use.
- As fast as you feel comfortably driving up to 10 to 15 mph (16 to 24 km/hr) over the posted speed limit.

4. Congratulations: you made it through your first day as an emergency vehicle operator! You leave work and are driving home for some much needed rest. As you approach a green light, you see and hear your coworkers from the next shift approaching the intersection perpendicularly. What should you do?

- Pull up to the intersection and stop, allowing your car to block other traffic.
- Speed up to make it through the intersection before the ambulance reaches it.
- Put on your right blinker and pull off to the right, coming to a complete stop.
- Stopping is the most important thing: right where you are in the middle of the road.

5. You are "on call" overnight at your home. In the middle of the night, your pager goes off, beckoning you for a emergency call. Thankfully, you applied for and obtained the appropriate permit for a "blue light" for your personal call. True or False: the blue light provides you and your personal vehicle the same privileges that red and white lights provide for an ambulance.

- True
- False



ACTIVITY TOURISM - YOU: THE AMBULANCE DRIVER

6. After a few days off, you are back at work when dispatch notifies you that you are needed to provide emergency care to a person who broke their leg following a fall from a ladder. The patient has a known seizure disorder and is actively having a seizure.

What special care do you use when approaching the scene?

- Drive very *very* fast, as the patient is probably critical.
- Nothing.
- Turn off your overhead flashing lights.
- Use your air horn when you arrive on scene to try to "snap" the patient out of their seizure.



7. While en route to the hospital with your patient, you are acutely aware that A) your patient is in pain and B) your crew is tending to the patient and may not be belted in with their seatbelts. What adjustments do you make to the operation of the ambulance?

- Take turns slowly and widely.
- Use roads you are familiar with, if possible, and try to avoid bumps, sharp turns and sudden stops.
- Verbally notify your crew before turning.
- All of these.

8. You are en route to another call later in the day. Most of the cars on the road do not pull over and stop in response to your lights and sirens, which is a usual occurrence. When they do not, you have to maintain a piece of your attention on their vehicle, because you cannot be sure if they see and hear you or not. What should you do?

- Use your PA (public address) system to verbally tell the drivers to pull over and stop.
- Keep focused on the road ahead of you. Slow down if necessary.
- Call 911.
- Ask someone else in your crew to write down license plates numbers so that you can call the police later and have them ticketed.

9. You never know how far you might have to drive at a moment's notice or how long you may be on a scene (with your engine running), so the ambulance you drive must never go below 1/2 on the gas gauge. You stop for gas and fill her up. Shortly after, you are dispatched to a reportedly unconscious elderly male. While en route, the unthinkable happens: a driver of a car thinks they can beat you across the road before you pass and you T-bone the car at 40 mph (65 km/hr). You were seatbelted, as were the other members of your crew, and a verbal check with your crew shows that you all feel you are okay. Your ambulance is only lightly damaged and is drivable. The car you hit has been considerable driver's side damage. What do you do next?

- Call to dispatch via radio to give them the location and severity of the accident and to have police and an ambulance dispatched to your location. Continue on to your initial call, which takes priority over your accident.
- Start taking names of witnesses to the accident.
- Don't move from where you are, as it is imperative for your eventual lawsuit that you look and act as injured as possible.
- Call to dispatch via radio to give them the location and severity of the accident, as well as to have a different ambulance dispatched to the original call and to have police and another ambulance dispatched to your location. If you can, check the driver

10. After a few weeks on the job, you realize that you love your work and wouldn't give it up for anything. You have learned, through training and through experience, that the most important concern you have while driving an emergency vehicle is:

- Speed
- Safety
- Playing with lights and sirens
- Lookin' good



ACTIVITY TOURISM - AUTOMOBILE VOCABULARY 1

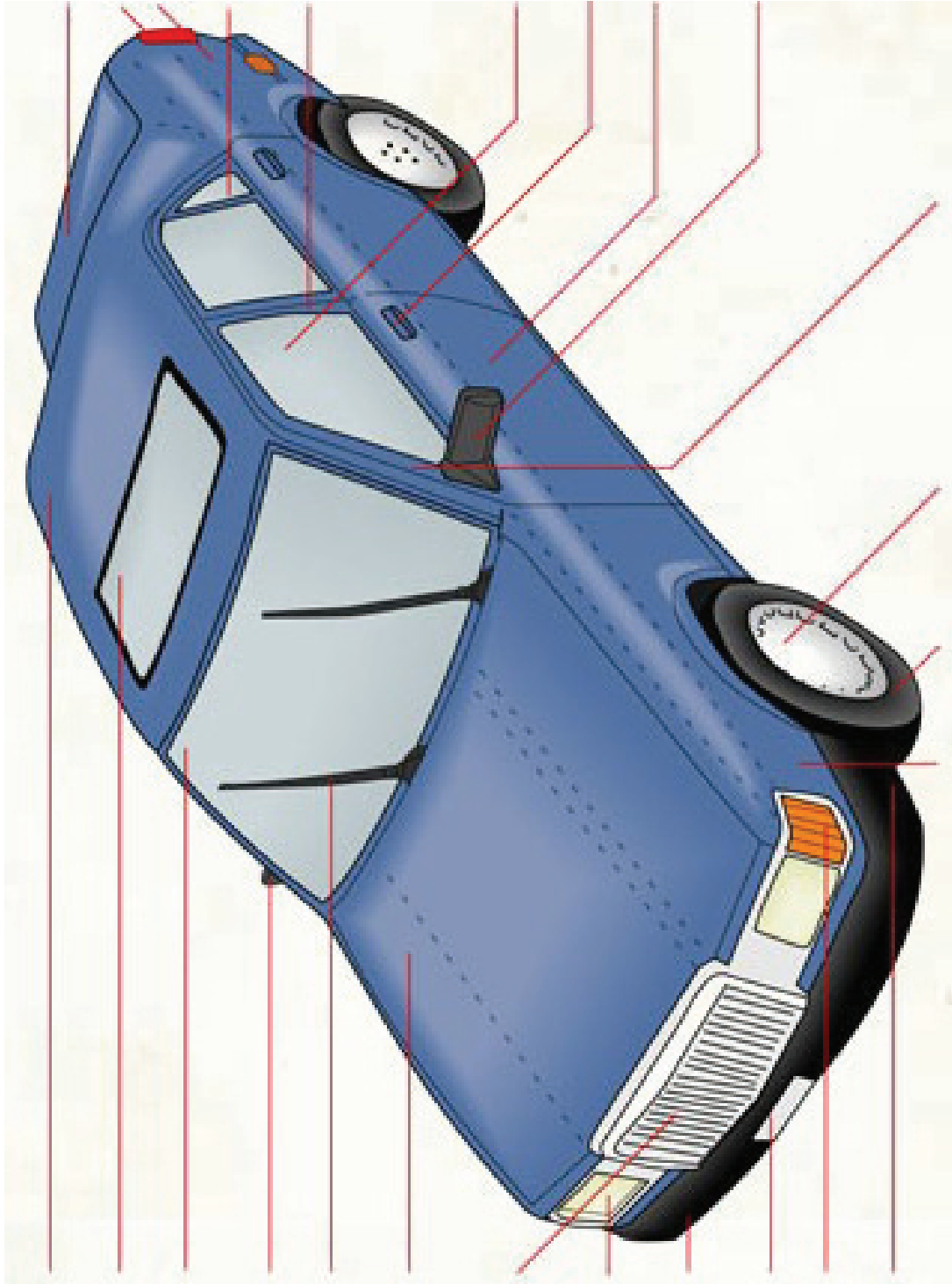

Source: The Visual Dictionary http://www.infovisual.info/05/001_en.html



ACTIVITY TOURISM - AUTOMOBILE VOCABULARY 2

AUTOMOBILE

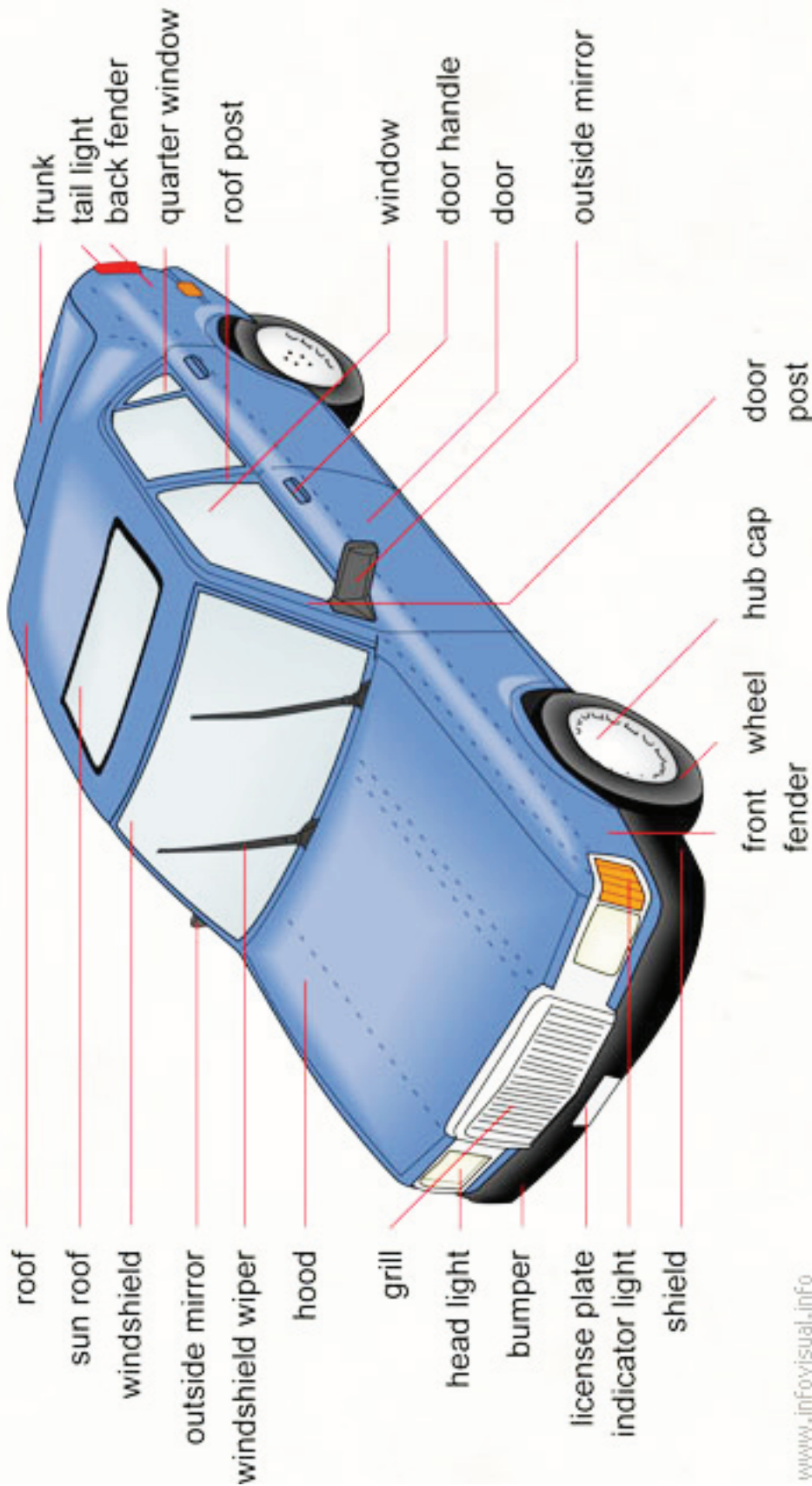

Source: The Visual Dictionary http://www.infovisual.info/05/001_en.html



ACTIVITY TOURISM - AUTOMOBILE VOCABULARY

Write the correct term that corresponds to each definition.

Road vehicle that is motor-driven and is used for transporting people.

Place for stowing baggage.	
Rear light.	
Side rear part of the body that covers the wheel.	
Window pane situated approximately above the rear wheel.	
Vertical structure that supports the top of the car.	
Mounted pane of glass.	
Part of the door used to open it.	
Opening used to enter the passenger compartment.	
External mirror used for looking backwards.	
Vertical structures that encase the windows.	
Piece of metal covering the hubs.	
Round object that turns around a central axel and allows the car to advance.	
Side fore part of the body that covers the wheel.	
Movable apparatus that protects against bumps.	
Amber light that is used to signal changes in the car's direction.	
Piece of metal that carries a number used to identify the automobile.	
Apparatus at the front and rear of a vehicle that protects the body from minor	
Plastic or metal decoration over the radiator.	
Cover of the engine compartment at the front of a car.	
Movable device, made partly of rubber, that wipes the windshield and rear	
External mirror used for looking backwards.	
The front window of a car.	
Movable part that allows the roof of a car to be partially opened.	
Upper part of a car, covering the passenger compartment.	



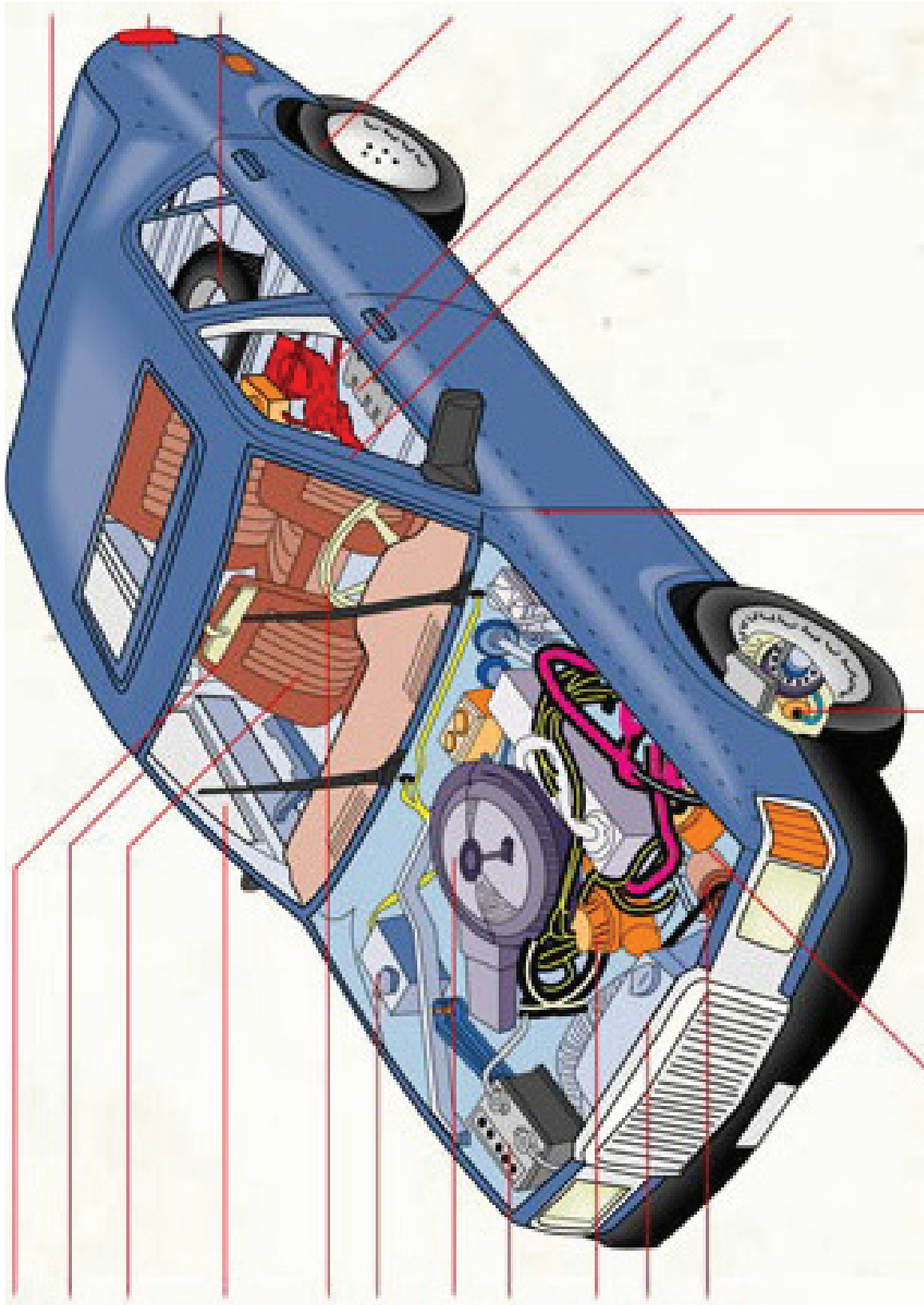

Source: The Visual Dictionary http://www.infovisual.info/05/001_en.html



ANATOMY OF AN AUTOMOBILE

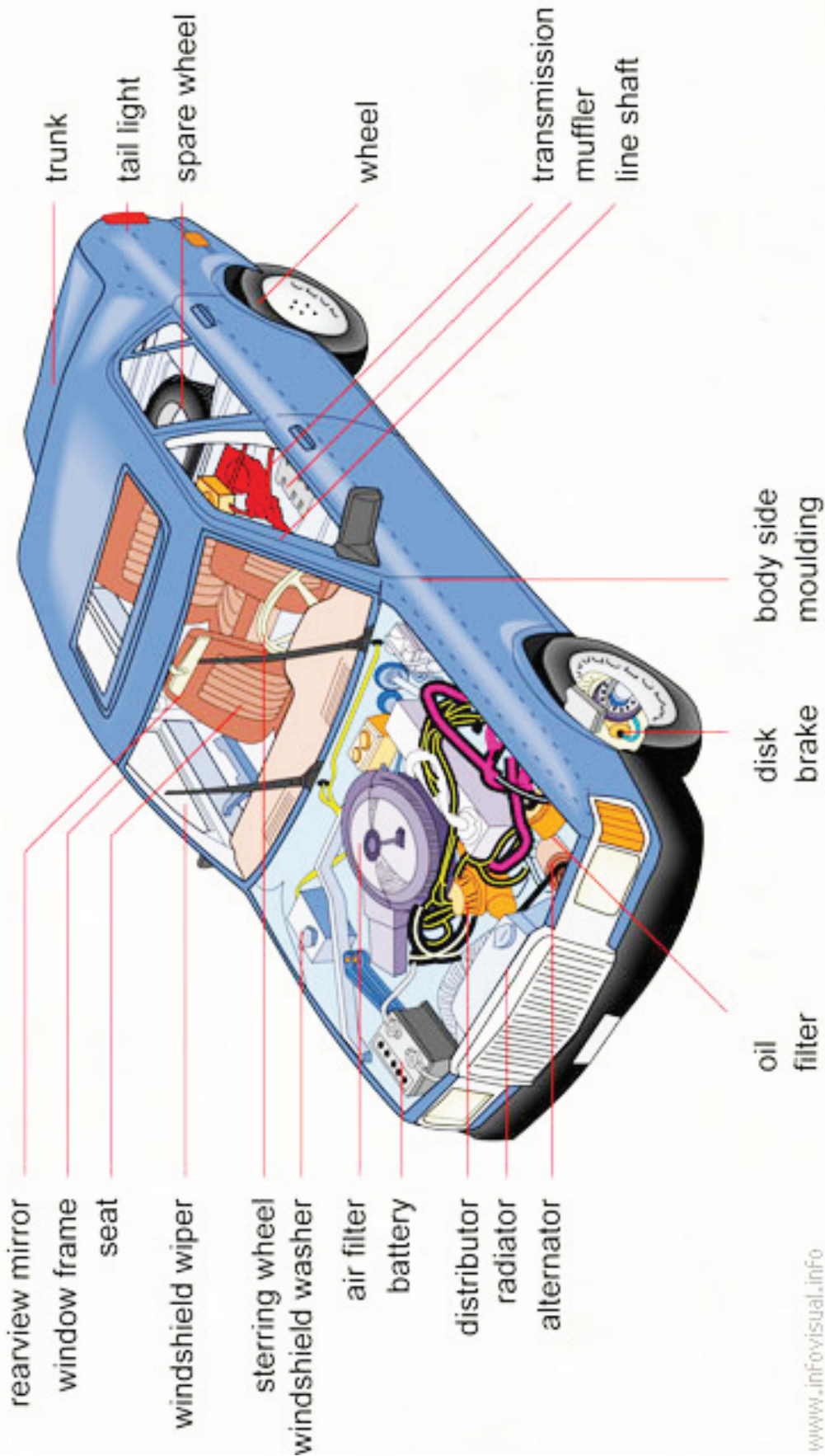

Source: The Visual Dictionary http://www.infovisual.info/05/001_en.html





ACTIVITY TOURISM - AUTOMOBILE VOCABULARY

Write the definition that corresponds to each term.

	anatomy of an automobile
	trunk
	tail light
	spare wheel
	wheel
	transmission
	muffler
	line shaft
	body side moulding
	disk brake
	oil filter
	alternator
	radiator
	distributor
	battery
	air filter
	windshield washer
	steering wheel
	windshield wiper
	seat
	window frame
	rearview mirror





ACTIVITY TOURISM - CHANGE A FLAT TIRE IN 10 STEPS

Re-order chronologically the 10 steps for changing a flat tire.

Remove the hub cap, if equipped, using the tapered end of the lug wrench. Using the other end of the lug wrench, loosen the lug nuts holding the wheel on. Do this while the wheel is still on the ground. All you are doing is loosening the nuts slightly, do not remove the lug nuts at this	
Remove the wheel and set it aside.	
Reinstall the hub cap. Put away the spare and all of your tools, and you are ready to drive away!	
Block the wheel diagonally opposite the flat on both sides of the tire to keep the car from rolling while it is being jacked up.	
Locate and remove your spare wheel, lug wrench, tire jack, and wheel chocks.	
Make sure you are well off the highway, parked on a hard, level surface. Turn on your emergency flashers. Place the car in park, or if you have a stick shift place the transmission in first or reverse gear. Engage the park-	
Place the jack underneath the car in the location specified in your owner's manual. Not doing so may cause the car to fall off the jack, damaging the car and possible causing injury to you. Using the jack handle, jack up the car until the flattened wheel is completely off the ground.	
Lower the car back to the ground. Using your lug wrench, tighten all of the lug nuts.	
Install the spare wheel, lining it up over the wheel studs. Thread the lug nuts back onto the studs, installing the tapered end of the nut towards the wheel. Be careful not to cross thread the lug nuts. Hand tighten the lug	

Read more: How to Change a Flat Tire in 10 Easy Steps | eHow.com http://www.ehow.com/how_5521220_change-flat-tire-easy-steps.html#ixzz26lo44LXc



How to Be a Wine Connoisseur

The world of wine is a fascinating culture. There's much to learn about wine, how it's made, what vineyards produce the best grapes and how to spot the top vintages.

Step 1

Know the jargon. The fastest way to master wine is to learn the vocabulary. For example, the "vintage" is the year the grapes from which the wine was made were harvested. The vintage year is clearly marked on most bottles. The word "magnum" refers to a large bottle of wine, equal to two bottles of regular size.

Step 2

Get to know the grapes. When connoisseurs talk about "varieties" or "varietals" they are speaking of the grape used to harvest the wine. White wine comes from the following grapes: chardonnay, riesling, sauvignon blanc, chenin blanc, pinot grigio (or pinot gris) and semillion. Red wines are produced from these grapes: cabernet sauvignon, merlot, pinot noir, shiraz (or syrah), zinfandel and grenache. Champagne comes directly from grapes grown only in Champagne, France.

Step 3

Learn about regions. Wine is harvested in certain "regions" of the world. The most famous wine regions are Bordeaux, Burgundy and Champagne in France and Napa Valley in California. Australia, Spain, Italy and many areas in California all have world-renowned wine regions. South Africa and California's Paso Robles are both "up and coming" wine regions.

Step 4

Know the critics. Wine critics are a key part of vino culture. Knowing their names will help you get by as a connoisseur. Here are a few good names to be with: Clive Coates, Stephen Tanzer and Paolo Tullio. If you come across any articles by these writers, read them as part of your wine education.

Step 5

Develop your taste buds. Wine is meant to be tasted and enjoyed. Train your nose and mouth to discern between tastes and fragrances so that you can intricately describe wine. Connoisseurs use adjectives to describe the wine tasting experience. For example, a Chardonnay might be described as "dry, medium bodied, with a hint of lemon, some melon, but a not too fruity, subtle finish". A Merlot might be described as "oaky, supple, light and fruity, deep and dark". A Cabernet may have a great intensity of flavor, full body and may be aged in oak. And finally a Pinot noir is a wine with a lighter body and less tannin. Other adjectives: floral, herbal, light body, balanced, full-bodied, good acidity.

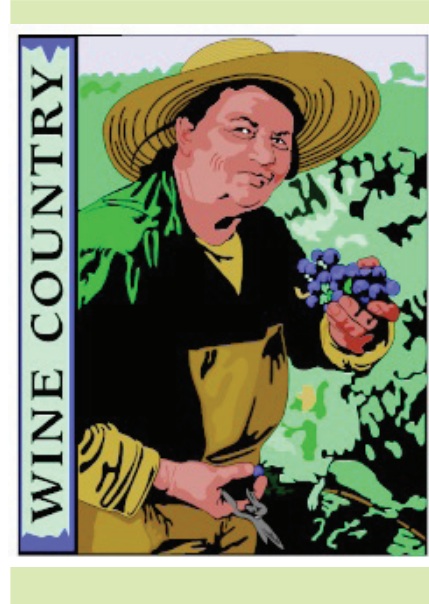

Source: www.ehow.com/how_2069948_be-wine-connoisseur.html



Match the terms and the definition.

1. vineyard

a) balanced

2. varietal	b) showing great promise: coming, promising
3. finish	c) to find something by chance
4. sommelier	d) a sweet or pleasant odor; a scent
5. magnum	e) thick wines, like port
6. late harvest	f) refers to the grape from which the wine is made. By law, the varietal must have at least 75% of that grape.
7. vintage	g) an oval sensory end organ on the surface of the tongue
8. up and coming	h) body of the wine
9. mouth feel	i) a large bottle of wine, equal to two bottles of regular size
10. light/thin body	j) to give the impression that
11. medium body	k) wine waiter
12. to come across	l) very watery
13. full body	m) the year the grapes from which the wine was made were harvested
14. to get by as	n) term describing the taste that remains in your mouth after wine has been consumed, spit, or swallowed (aftertaste)
15. taste buds	o) piece of land on which vines (= plants which produce grapes) are grown
16. fragrance	p) term applied to wines made from grapes left on the vine longer than usual. Late harvest is usually an indication of a sweet dessert wine, such as late harvest Riesling



Discuss the following questions.

1. Do you drink alcohol? Do you like red wine?
2. How much do you drink a week?
3. What do you think are the effects of drinking red wine? Do you believe the reports about its health benefits?
4. What are some problems that could be associated with the research findings concerning the benefits of red wine?
5. Would you like to take a pill that is derived from red wine and grapes?
6. What do you think about research for obesity treatments that don't involve weight-loss?
7. What do you expect from a good wine? Put the following elements from most to least important:
 - reasonable prices
 - variety of grapes
 - renowned vineyard
 - corked wine
 - tastes and fragrances
 - vintage
 - region of the world
8. Which wine from your country would you recommend to a foreign visitor?



How to Pair Food and Wine

Simple rules to get started pairing food and wine.

Drink what you like.

What you like to drink always takes precedence over any recommendation that someone might make.

Start by thinking about the dish or meal as a whole. What are its dominant characteristics?

Is it mild or flavorful?

Is it fatty or lean?

Is it rich or acidic?

Keep flavors in balance.

Match mild foods with mild wines. Match big, flavorful foods with big, flavorful wines. (For example, pair a bold-flavored Pepper Steak with a spicy, bold red Zinfandel.)

Similarly you generally want to match the richness of the food and the richness of the wine. (For example, pair a rich Chicken in Cream Sauce with a rich Chardonnay.)

Cleanse the palate with tannins or acids.

If you're eating a relatively rich, 'fatty' dish and thinking about drinking a red wine (when you eat a beef steak, for example) you probably want a wine with some good tannins* in it to help cleanse the palate.

If you're eating a very rich, 'fatty' dish and thinking about drinking a white wine (when you eat fried chicken, for example) you probably want to contrast the meal with a refreshingly crisp acidic wine such as a Sauvignon Blanc. You can ignore this rule for dishes that are just relatively fatty - such as Chicken in Cream Sauce - which will probably do better with a rich Chardonnay that can match their rich flavors.

Match Acids with Acids

If you're eating a dish with a strong acidic content

(such as Shrimp with Lemon or Pasta with Tomato Sauce) pair it with an acidic wine that can keep up with the acids in the food.

Acidic Wines and Cream Don't Mix

Rich cream sauces will usually clash with an acidic wine like a Sauvignon Blanc.

Think about it this way...If you squeezed lemon juice into a cup of milk, would it taste good?

Wine and Strong Spices

Strong spices, such as hot chili peppers in some Chinese or Indian food, can clash and destroy the flavors in a wine. In most cases, wine is not the ideal thing to drink. However, if wine is what you must have, consider something spicy and sweet itself such as an off-dry Gewurtztraminer or Riesling.

When In Doubt...

Remember that foods generally go best with the wines they grew up with.

So if you're eating Italian food, think about having an Italian wine.

This isn't a requirement, but often helps simplify the decision.

More About Tannins

Tannins can come from many places, including the skins of the grapes used in winemaking as well as the wood barrels a wine may have been aged in. Tannin tastes similar to the flavor you would get if you sucked on a tea bag. This astringent flavor is what helps strip the fats from your tongue and thereby cleanse the palate of the rich fats from a meal and provide a refined, refreshing drink.

Some studies have also indicated that tannin might help reduce the risk of coronary heart disease. Specifically, tannin might suppress the creation of a peptide that causes arteries to harden.

Source: www.foodandwinepairing.org



Match the terms and the definition.

1. corkscrew noun a. sampling different types of wine

2. counter noun	b. place for people to use a toilet and wash hands
3. fine dining noun	c. long hollow plastic stick for drinking out of
4. free refills adjective + noun	d. hot flavor
5. pitcher, jug noun	e. flat area often used for placing dishes on or preparing food
6. to pour verb	f. dry flavoring added to food
7. restrooms noun	g. dispense liquid from a container
8. seasoning noun	h. cooked for longer than average
9. side dish noun	i. choice of food that goes with a main meal
10. sour adjective	j. beverages that can be filled again without any cost
11. spicy adjective	k. acid or fermented taste
12. straw noun	l. a very expensive eating establishment
13. well- done	m. a place where wine is made, tasted, and sold
14. wine list noun	n. a menu of all of the wine you can order from the glass, liter, or bottle
15. wine tasting adjective	o. a container with a spout to pour water, beer, or other beverages out of
16. winery noun	p. tool for removing the cork from the top of a wine bottle.



Discuss the following questions.

1. How do you usually pair food and wine?
2. Think about the text excerpt you just read, can you resume the rules for pairing food and wine in a few words?
3. In a liquor shop, do you ask for advice from the seller ?
4. What flavors do you like in a dish? What flavors do you like in a wine?
5. What are tannins?
6. What are the benefits of tannins, according to some recent studies?
7. What is a neck tag? What is a wine rack?
8. Do you collect wine corks? Do you know anyone who does?
9. Wine makes a lovely and thoughtful gift for any occasion. What type of wine do you usually buy as a gift?
10. What do you know about home wine making?
11. What do you think about organic wines?





AGRO-TOURISM - FISHING VOCABULARY

Use the following words to make sentences. If the words are not familiar to you, check pages 2, 3 and 4.

1. fly rod

2. fly reel	
3. artificial fly	
4. fishhook	
5. spinning rod	
6. open-face spinning reel	
7. spinner	
8. fishing jacket	
9. waders	
10. tackle box	
11. creel	
12. landing net	
13. disgorger	
14. float	
15. fishing holiday	
16. fishing sounder / GPS	
17. fishermans knot	



AGROTOURISM - FISHING VOCABULARY

fishing vest



+ tackle box



creel



+ waders

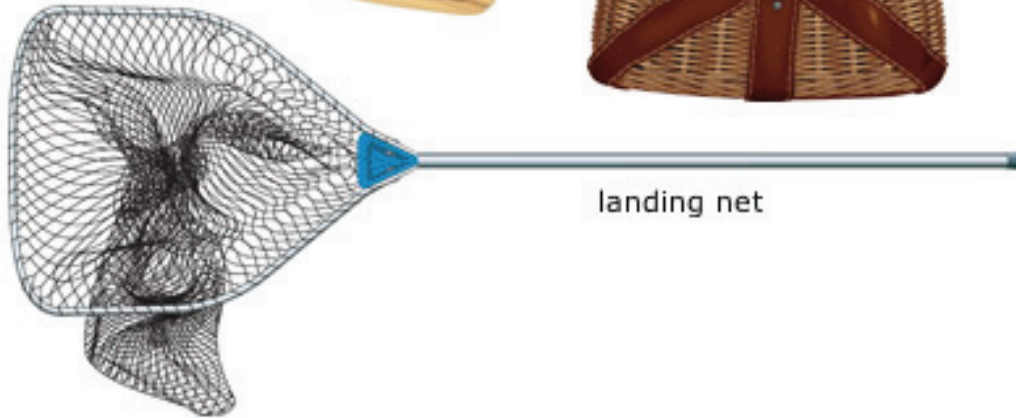

landing net

+ spinning rod



Source: Merriam-Webster Visual Dictionary Online
http://visual.merriam-webster.com/sports-games/outdoor-leisure/fishing/casting_6.php



HOW TO FISH

Choose a fishing location. Make sure to fish in water that actually has fish in it. If there aren't any fish, you aren't going to catch anything. Many newspapers have local fishing reports that will list locations and tell you what fish, if any, are biting and what they're biting on.

Once you have some idea of what fish you're looking to catch and what they're eating, you can pick the right bait. You need hooks that will FIT INTO the fish's mouth. #1 hooks work well for many things, but size 8 to 5/0 will work well for some fish. Ask your local tackle shop about the hook sizing system (i.e. 6,4,2,1,1/0, 2/0). The smaller the hook the better the chance of a bite, also a very thin line will result in more bites. Making a hook knot is kind of difficult with small hooks. Ask a tackle shop owner or another fisherman to teach you.



Because fish eat insects and aquatic life, there are millions of effective baits to choose from. The old standards are tough to beat, though. Consider using worms, salmon eggs, grasshoppers, or synthetic baits--Power Bait, for example--that are made to resemble and smell like live bait. You can either purchase live bait at the local angling shop, or you can gather your own. Many anglers gather worms in a lawn after a rain or late at night with a flashlight. You can find grasshoppers along the banks of a stream.

If bait is plenty start feeding some bait around the place where you want to fish. Repeat this regularly especially in swift streams.

Choose the appropriate bait fishing method:

If the water is quite swift--a small river or stream--it is probably best to attach weights to your line about 12" above your bait. By weighting down your line you will keep your bait in place about an inch above the floor of the water—right where fish are likely to be hunting.

If the water is not moving rapidly, as in a lake or a large, slow river, consider using a bobber. A bobber is generally a brightly colored plastic device that floats on the surface of the water. The bobber will attach easily to your line, and you should place your bait below the bobber. Adjust the distance between the bobber and your bait to accommodate the depth of the body of water. You want your bait located where the fish are, so consider shortening and lengthening the distance between bait and bobber, or even adding small weights (also called split shot) to keep your bait perfectly suspended under water. Cast your line and wait for a bite. You can tell if a fish is biting by touch, by watching a loose line or a bobber, or by attaching a bell to the end of your rod.

Waiting for a bite can take a lot of patience, but that's what fishing's all about. Using light tackle combined with feeding around your bait will produce bites much quicker. When you catch a fish feed a little extra, because fish often live in smaller or larger groups that you want to stay around.

Wait. That said, if you're waiting for 10-15 minutes and you still haven't gotten a bite, try casting somewhere else and wait again.

Source: <http://www.wikihow.com/Fish>





AGROTOURISM - FISHING QUIZ

Discuss the following questions.

1. Are you male or female?

- Female
- Male

2. How long have you been fishing?

- Years
- 1-5 Years
- 5 + Years

3. How often do you go fishing?

- Daily
- Weekly
- Monthly
- Annually

4. How much would you spend on fishing per year (including equipment, tackle, bait etc)?

- 10,000 euro +
- 5000 – 9999 euro
- 2500 – 4999 euro
- 500 – 2499 euro

5. How much do you spend online on fishing gear annually?

- 1000+
- 750 – 999 euro
- 500 – 749 euro
- 250 – 499 euro

6. Where do you fish?

- Saltwater
- Freshwater
- Both

7. Do you choose your holiday destinations around fishing?

- Yes
- No

8. Do you subscribe to any fishing magazines?

- Yes
- No

9. What is your biggest unanswered question to do with fishing?

10. Is fishing a personal venture or with friends or family?

- Personal Venture
- Friends
- Family

11. Do you belong to a fishing club?

- Yes
- No

12. What are you interested in buying in the next 12 months?

- Boats
- Reels
- Rods
- Tackle
- Insurance
- Charters
- Fishing Holiday
- Fishing Sounder / GPS

13. What other interests do you have?

- Camping
- 4WD
- Boating
- Hiking
- Golf
- Surfing



POPULAR SPORTS IN THE U.S.

TRADITIONAL SPORTS

- Baseball, softball (played in school, all have at least
- American football basic level of player-competence;
- Basketball highly-developed professional levels)

ESTABLISHED SPORTS

- Tennis
- Swimming & Platform Diving, Water skiing, Scuba Diving
- Track and field, cross-country, road racing (running)
- Volleyball (California beaches)
- Skiing (Alpine and Nordic), archery, riflery, pistol shooting

NEWER SPORTS

- Ice hockey, Soccer & Rugby football
- Jai-alai

TRADITIONAL INDOOR SPORTS

- Bowling, roller derby, boxing, wrestling, esp. professional
- Pool and billiards, card games (poker, etc., not bridge, etc.)

NEWER INDOOR SPORTS

- Squash, racquetball, handball (note difference cf Europe)
- Aerobics, jazzercise, jazz dance, gymnastics, ice-skating

NEWER OUTDOOR SPORTS

- Hang-gliding, parachuting, windsurfing
- Mountain climbing, scuba diving, "wilderness survival" courses

NEWER "ENDURANCE" SPORTS

- Marathon races, "Citizen" road races, X-C ski marathons
- Triathlon events (Swim, bicycle, run)



MOTORIZED SPORTS

- Formula One racing, Stock car racing, Demolition Derby

ANIMAL SPORTS

- Horse racing (horse and jockey, trotting)
- "Show horse" events (dressage, jumping)
- Rodeo, hunting [with dog], cockfights, greyhound races

MAJOR SPORTS EVENTS

Olympics, Super Bowl, College "Bowl" Games, World Series, Stanley Cup, Kentucky Derby, New York & Boston Marathons, Hawaii Ironman, NBA Playoffs, U.S. Open and Masters Tournaments (Golf), Indy 500

MAJOR STADIA (NAMES KNOWN, LANDMARKS)

Madison Square Garden, Boston Garden; The Astrodome (Houston), SuperDome (New Orleans), MetroDome (Minneapolis), Kingdome (Seattle), Georgia Dome (Atlanta); Rose Bowl, Orange Bowl, Cotton Bowl (vs Super Bowl); Ebbets Field, Polo Grounds; Yankee Stadium, Shea Stadium, [the former] Candlestick Park, Los Angeles Coliseum; Busch Stadium The Meadowlands, Arrowhead Stadium, Lambeau Field, Soldiers Field, Foxboro Stadium, RFK Stadium Wrigley Field (Chicago), Fenway Park (Boston)

Source: <http://www.uta.fi/FAST/US7/REF/popsport.html>





POPULAR SPORTS IN THE U.S.



POPULAR SPORTS IN YOUR COUNTRY





ACTIVITY TOURISM - SPORTS SLOGANS

One spirit, one team, one win.

Talk with your feet. Play with your heart.

Stand tall, talk small, play ball.

Respect all, fear none.

One spirit, one team, one win.

Save the drama for your mama, we're here to play.

We got bigger balls than baseball players.

Together we stand, together we fall.

Hockey: Making dentists rich since 1875.

11 players 1 heartbeat

1 team 1 mission

There is no I in Team.

Real men wear skates.

A team above all. Above all a team.

A bad place to be is between me and the

They never said it would be easy.
They only said it would be worth it.





ACTIVITY TOURISM - SPORTS VERBS AND NOUNS

Add the correct verb PLAYING, GOING, DOING.
What kind of equipment is used during these sports?

aerobics	
badminton	
ballet	
baseball	
basketball	
cricket	
football	
golf	
gymnastics	
hockey	
jogging	
karate	
martial arts	
rugby	
running	
skating	
skiing	
soccer	
tennis	
volleyball	
yoga	



CULTURAL TOURISM - DIVERSITY CARDS 1



ENJOY LANGUAGE

DIVERSITY FLASHCARDS
WALK A MILE IN MY SHOES

www.enjoy-language.se

A project financed under the Life Long Learning Programme
(LLP-Ldv/TOI/SE/11/1383 - 2011-1-SE1-LEO05-08376)

WALK A MILE IN MY SHOES

Male
16
Finnish
Heterosexual
Lutheran



www.enjoy-language.se

WALK A MILE IN MY SHOES

Male
20
American
Co-habiting
1 child



www.enjoy-language.se

WALK A MILE IN MY SHOES

Female
65
Australian
Widowed
With a
disability



www.enjoy-language.se

WALK A MILE IN MY SHOES

Male
72
Bulgarian
Married
No children



www.enjoy-language.se

WALK A MILE IN MY SHOES

Female
15
Polish
Single
Catholic



www.enjoy-language.se

WALK A MILE IN MY SHOES

Male
48
Russian
Separated
3 children
With a
disability



www.enjoy-language.se

WALK A MILE IN MY SHOES

Female
36
Nepalese
Married
2 children
Hindu



www.enjoy-language.se

CULTURAL TOURISM - DIVERSITY CARDS 2

WALK A MILE IN MY SHOES

Female
40
French
Single
Bisexual



www.enjoy-language.se

WALK A MILE IN MY SHOES

Female
38
British
Single
With a
disability



www.enjoy-language.se

WALK A MILE IN MY SHOES

Female
22
Finnish
Single
Muslim



www.enjoy-language.se

WALK A MILE IN MY SHOES

Male
52
Finnish
Separated
2 children



www.enjoy-language.se

WALK A MILE IN MY SHOES

Female
19
Mexican
Heterosexual
Co-habiting
Pregnant



www.enjoy-language.se

WALK A MILE IN MY SHOES

Female
16
Vietnamese
Single
With a
disability



www.enjoy-language.se

WALK A MILE IN MY SHOES

Male
61
Swedish
Widowed
2 children



www.enjoy-language.se

WALK A MILE IN MY SHOES

Female
15
Japanese
Bisexual
Single



www.enjoy-language.se

CULTURAL TOURISM - DIVERSITY CARDS 3

WALK A MILE IN MY SHOES

Female
14
Norwegian
Single
Wheelchair
user



www.enjoy-language.se

WALK A MILE IN MY SHOES

Female
84
Canadian
Widowed
Wheelchair
user



www.enjoy-language.se

WALK A MILE IN MY SHOES

Male
17
Nigerian
Single
Muslim



www.enjoy-language.se

WALK A MILE IN MY SHOES

Male
19
Hungarian
Single
Wheelchair
user



www.enjoy-language.se

WALK A MILE IN MY SHOES

Female
15
Moldavian
Heterosexual
Orthodox
Christian



www.enjoy-language.se

WALK A MILE IN MY SHOES

Female
16
Brazilian
Single
Catholic



www.enjoy-language.se

WALK A MILE IN MY SHOES

Male
47
Albanian
Married
4 children



www.enjoy-language.se

WALK A MILE IN MY SHOES

Male
70
South African
Widowed
2 children



www.enjoy-language.se



CULTURAL TOURISM - DIVERSITY CARDS

WALK A MILE IN MY SHOES

TAKE A STEP FORWARD IF...

- You can use all forms of public transport.
- You can vote in national and local elections.
- You can travel freely to other countries.
- You can purchase alcohol.
- You can drive a car.
- You can get a passport.
- You can adopt children.
- You can get a bank loan.
- You can get a job.
- You can party in the local pub/night club.
- You can dress as you like when out in public.
- You have never encountered any serious financial difficulty.
- You have adequate social and medical protection for your needs.
- You can celebrate the most important religious festivals with your relatives and close friends.
- You feel your language, religion and culture are respected in the society where you live.
- You feel that your opinion on social and political issues matters, and your views are listened to.
- Other people consult you about different issues.
- You know where to turn for advice and help if you need it.
- You have never felt discriminated against because of your origin.
- You can go away on holiday once a year.
- You can invite friends for dinner at home.
- You have an interesting life and you are positive about your future.
- You feel you can study and follow the profession of your choice.
- You are not afraid of being harassed or attacked in the streets, or in the media.

