



MARMARA
ÜNİVERSİTESİ

Köklü geçmiş, güçlü gelecek...



Nadir toprak iyonları katkılı oksit camlarından beyaz ışık yayılımı
(White light emission from rare earth ions doped oxide glasses)

Murat Erdem



Glass Performance Days 2018 Istanbul, TURKEY

Marmara Üniversitesi Fizik Bölümü
Marmara University, Department of Physics, Istanbul 34722, Turkey

Nadir Toprak İyonları Katkılı Camlar (Rare Earth ions doped Media)

Cam Lazerler

Schott, Silika esaslı cam lazeri (emisyon: $1 \mu\text{m}$)



Schott, Fosfat esaslı Er lazer camı (emisyon: $1.5 \mu\text{m}$)

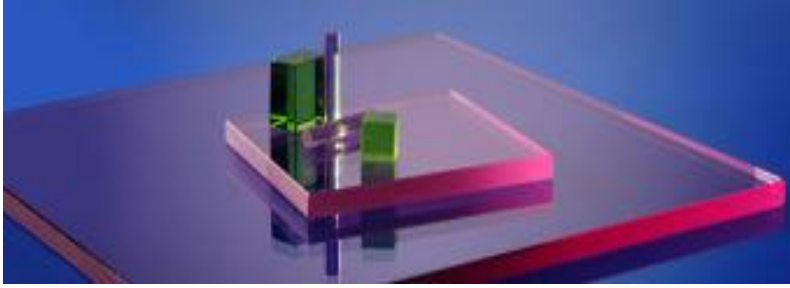

Hoya, Fosfat esaslı Nd Lazer camı (emisyon: $1.06 \mu\text{m}$)



3/13/2018



Cam fiberler : Optik yükselteç (EDFA)

Erbiyum katkılı silika esaslı cam fiber

Erbium-doped fiber

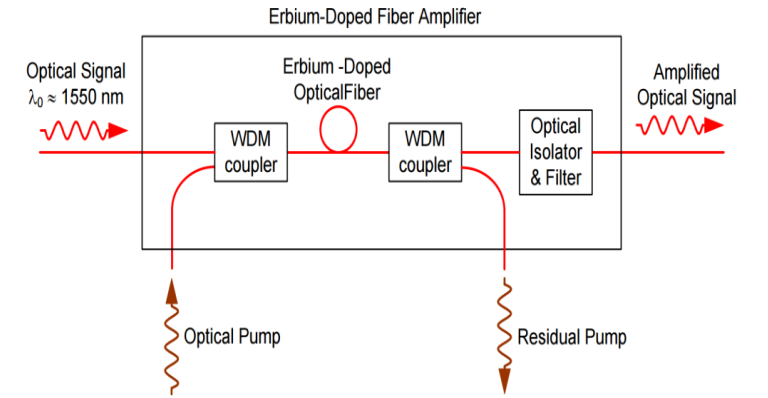
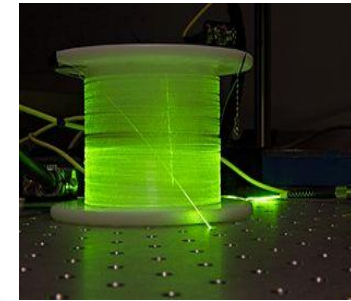
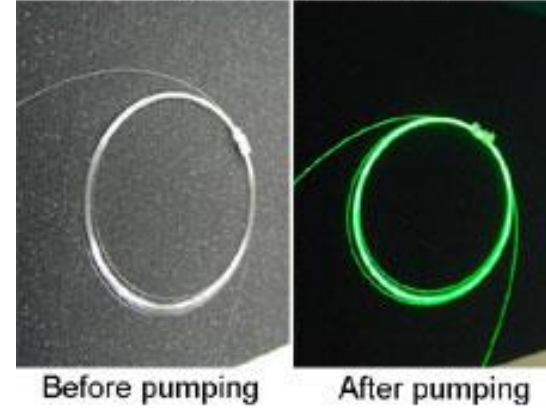

Nadir Toprak İyonları Katkılı Camlar (Rare Earth ions doped Media)

Güneş Pillerinin verimini artırmada
Enerji Transferi yoluyla ışımaya yapan camlar

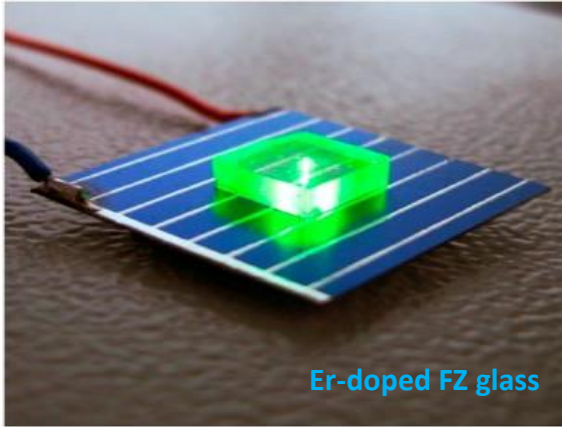

Er-doped FZ glass

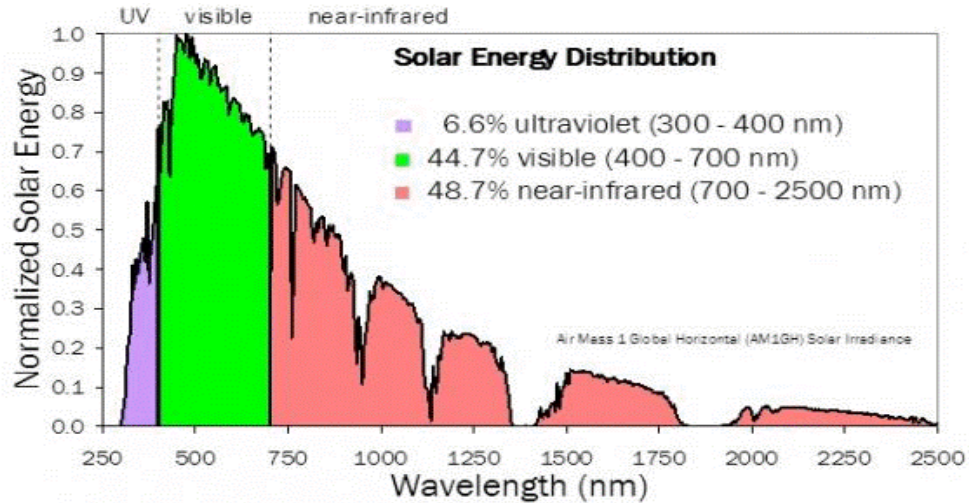
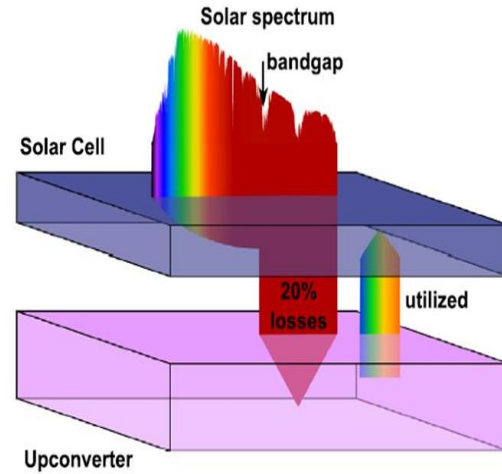

Optik Sıcaklık Sensörleri

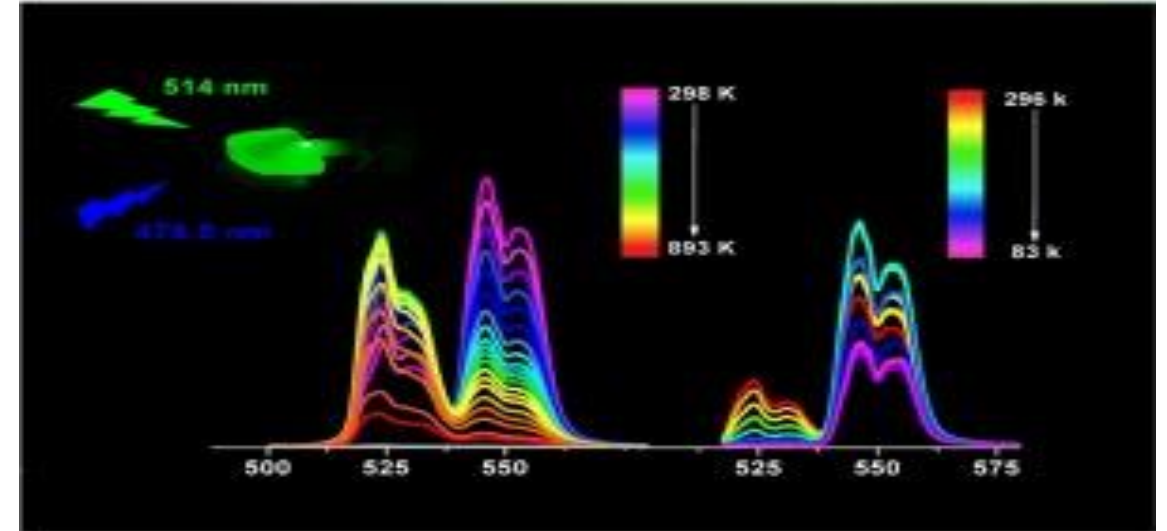

Er³⁺ katkılı tellür esaslı cam

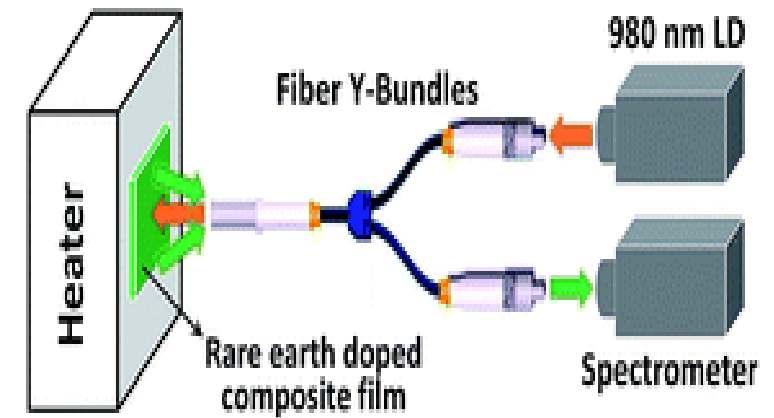



Camlar

Amorf katılardır
Kristal yapıda değildir
Uzun mesafeli düzenli yapıda değildir
Dondurulmuş sıvı gibidirler

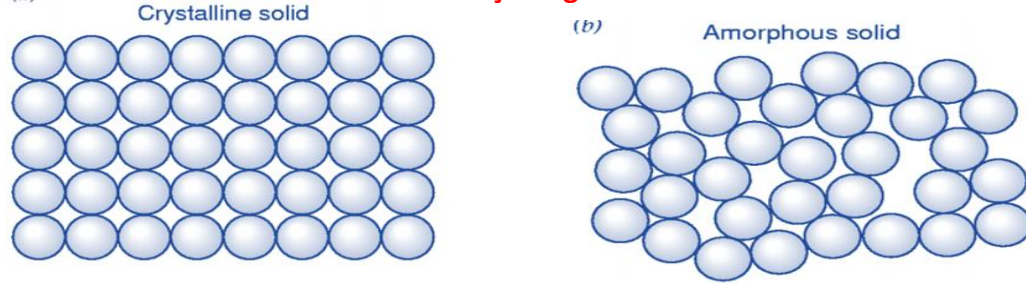

Türlerine göre Camlar

Some classes of glasses

OXIDES

SiO₂
GeO₂
BeO₃
P₂O₅

METALLIC

Fe - Ni
P - B
Cu - Zn

HALIDES

ZnCl₂
BeF₂
ZrF₄
AlF₃
InF₃
GaF₃

CHALCOGENIDES

Ga₂S₃ - La₂S₃
As₂S₃, As₂Se₃
Ge - Se

ORGANICS

polymers

Silicates
Phosphates
Borates
Germanates
Tellurites
Fluorozirconate
Sulfides
Chalcogenides
Fluoroindates
Antimony
Tungstates

Temel Farklılıklar

Fizikokimyasal özellikleri

Hazırlanış Yöntemleri

Geçirgenlik Penceresi

Düşük fonon enerjisi

Önemlerine göre Camlar

Fonon enerjilerine göre camlar

Bazı cam türlerinde en yüksek fonon enerjileri

Camlar	Fonon Enerjisi (cm ⁻¹)
Borate	~1400
Phosphate	1100-1200
Silicate	~1100
Germanete	~900
Tellurite	~700
Fluoroindates	~500
Sulfide(Ca,La)	~450

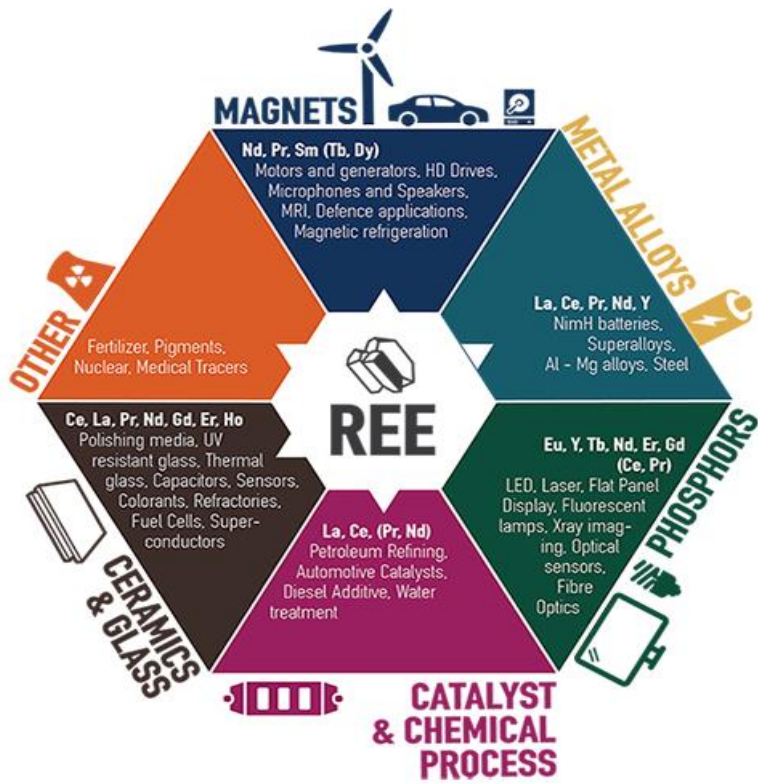

Nadir Toprak Elementleri

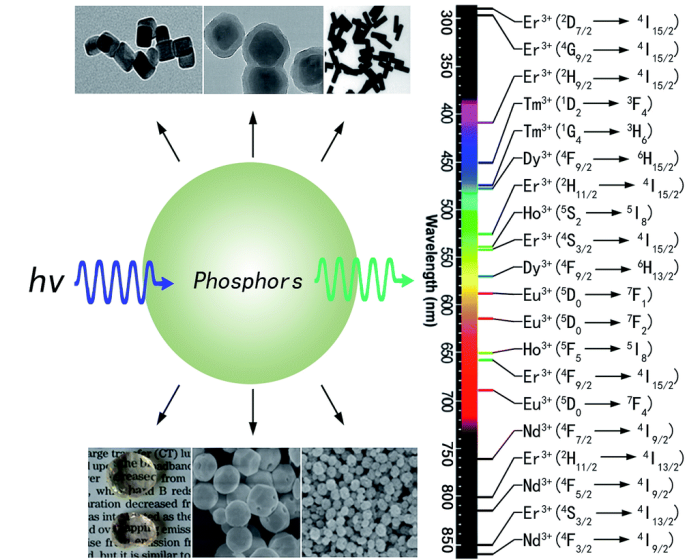
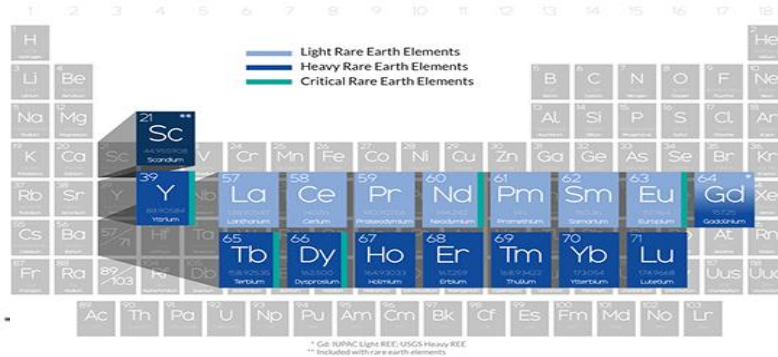

Rare Metals in a smart phone

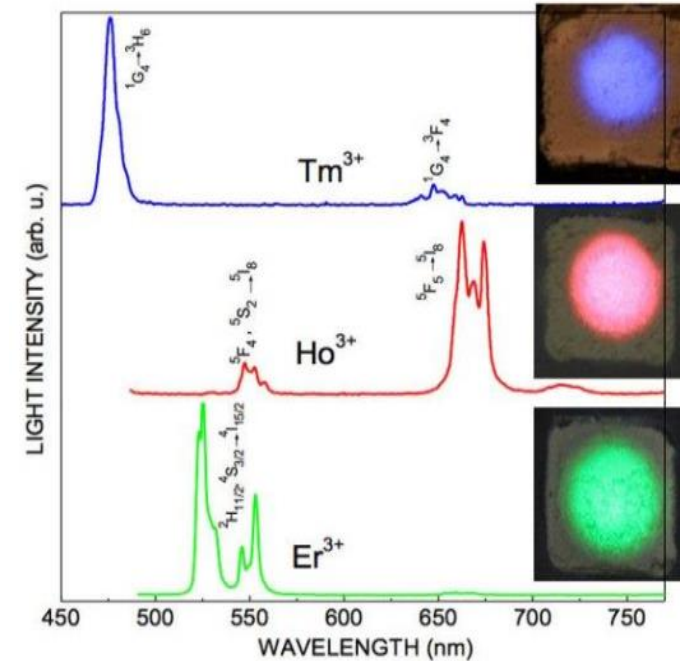
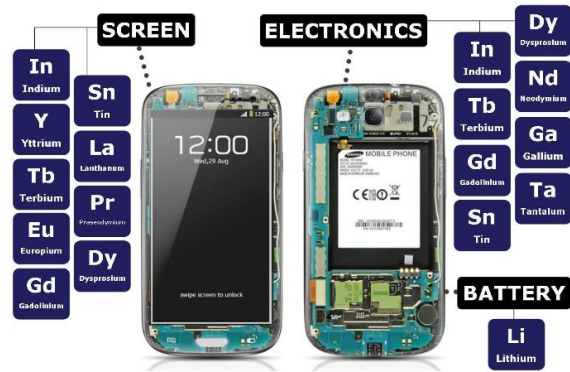

Ho³⁺, Tm³⁺ ve Er³⁺ katkılı GdVO₄ nanotozları

Üst Enerji Transfer Süreci Upconversion

Making 1x **blue** out of 2x **red**

Enerji Diyagramı

Energy level
diagram

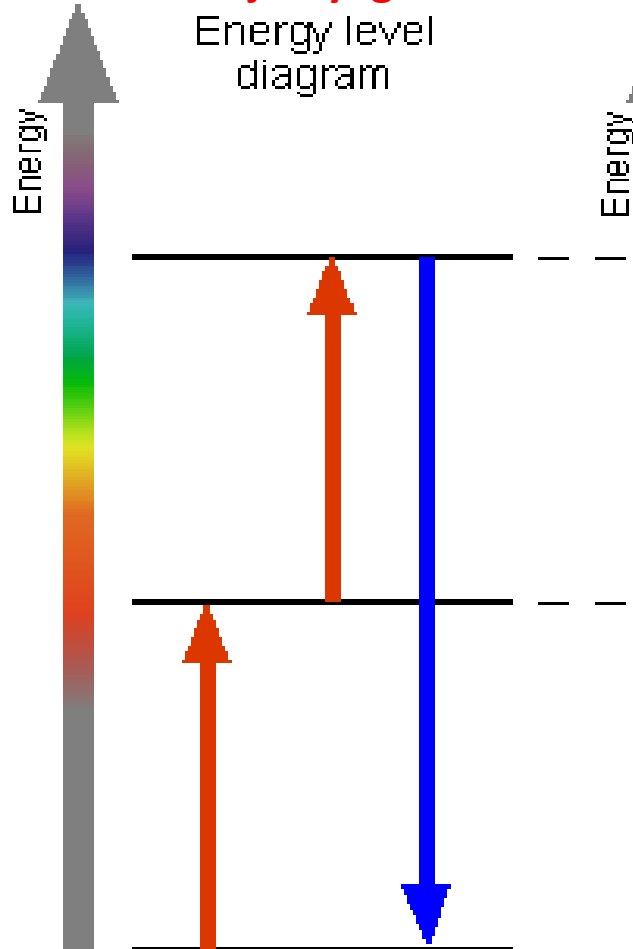

Analogy from
everyday life

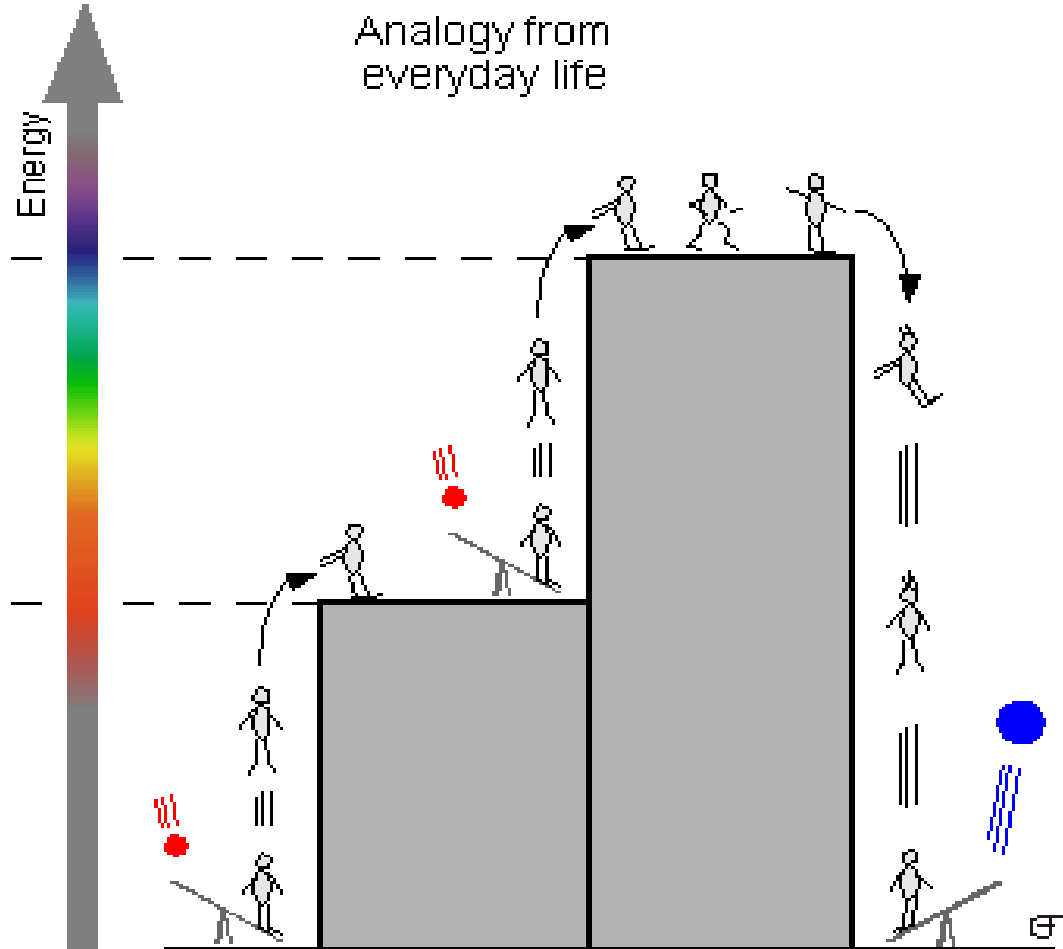

<https://alchetron.com/Photon-upconversion>

3/13/2018



Glass Performance Days 2018 Istanbul, TURKEY

Geleneksel Cam Hazırlama Tekniđi





Deneysel Çalışma Sonuçlarımız



* Çalışma grubu öğrencimiz Ayfer KAYA 'nın master tezi sonuçlarından alınmıştır

TZ



TZEY



TZY-D



TZY



TZET



TZEY-D



TZE



TZTY



TZTY-D



TZT



TZETY



TZETY-D



T: TeO₂, Z:ZnO₂, Y: Yb₂O₃, E: E₂O₃, T: Tm₂O₃
D: Tm₂O₃ mol yüzdesi diğer örneklerle göre yarıya düşürülmüş

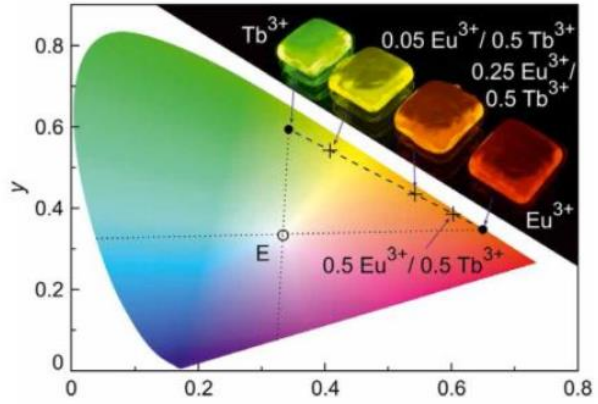
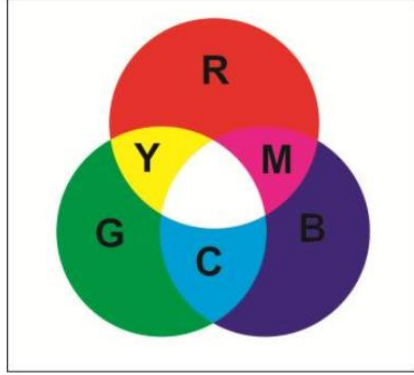

Dalga boyuna göre Güneş enerjisinin dağılımı

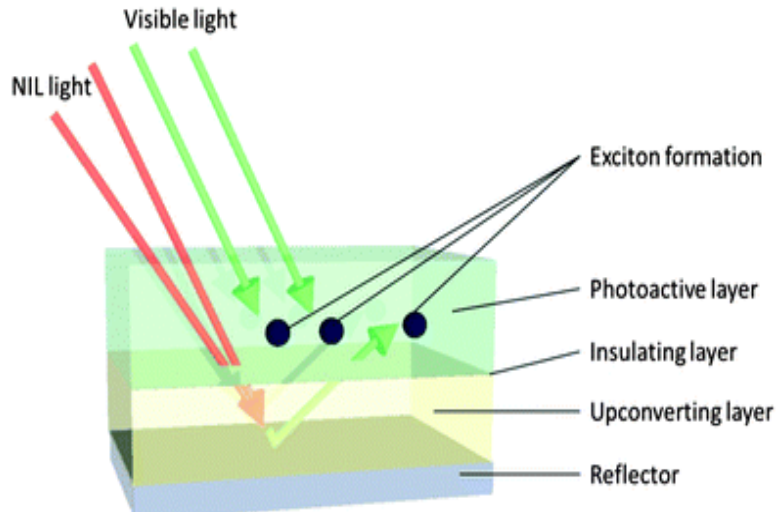
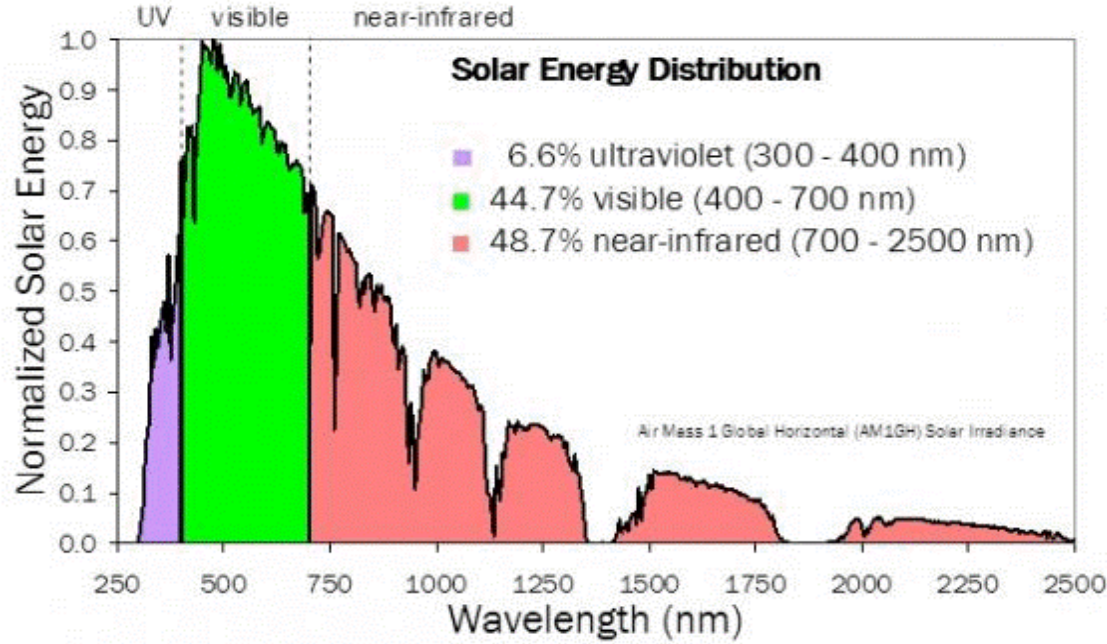

5/15/2010

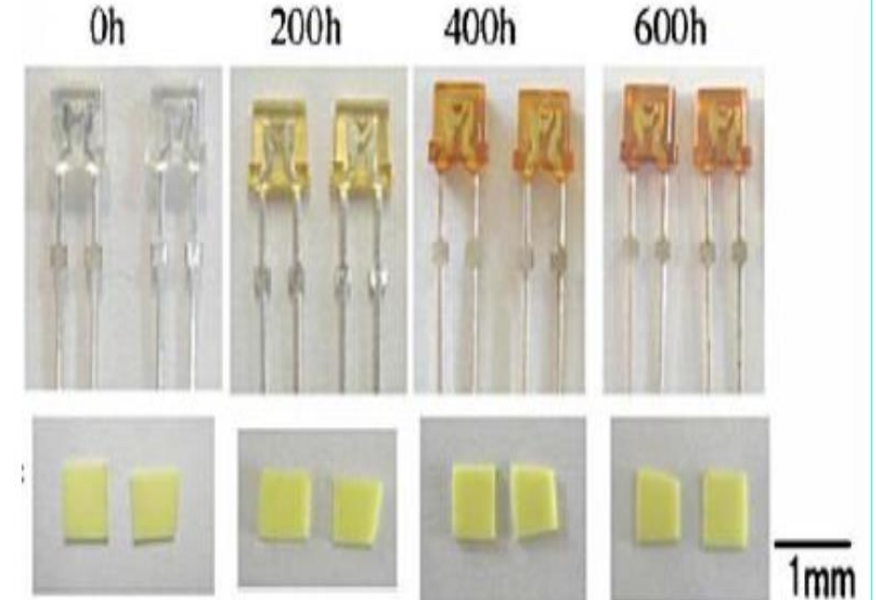

Organik reçine tabanlı beyaz LED (birinci sıra)

Ce:YAG seramiklerinin (ikinci sıra)



Teşekkürler



Prof. Dr. Gönül ÖZEN ERYÜREK



Sevcan TABANLI

